

A
B
C

SECTION SC

STARTING & CHARGING SYSTEM

CONTENTS

<p>SERVICE INFORMATION 2</p> <p>PRECAUTIONS 2</p> <p style="padding-left: 20px;">Precaution for Supplemental Restraint System (SRS) "AIR BAG" and "SEAT BELT PRE-TENSIONER"2</p> <p style="padding-left: 20px;">Precaution for Power Generation Voltage Variable Control System2</p> <p>PREPARATION 3</p> <p style="padding-left: 20px;">Special Service Tool3</p> <p style="padding-left: 20px;">Commercial Service Tool3</p> <p>BATTERY 4</p> <p style="padding-left: 20px;">How to Handle Battery4</p> <p style="padding-left: 20px;">Trouble Diagnosis with Battery Service Center6</p> <p style="padding-left: 20px;">Removal and Installation6</p> <p>STARTING SYSTEM 8</p> <p style="padding-left: 20px;">System Description8</p> <p style="padding-left: 20px;">Wiring Diagram - START -9</p>	<p style="padding-left: 20px;">Trouble Diagnosis with Starting/Charging System Tester (Starting)10</p> <p style="padding-left: 20px;">Removal and Installation13</p> <p style="padding-left: 20px;">Disassembly and Assembly16</p> <p style="padding-left: 20px;">Inspection After Disassembly18</p> <p>CHARGING SYSTEM 19</p> <p style="padding-left: 20px;">System Description19</p> <p style="padding-left: 20px;">Wiring Diagram - CHARGE -21</p> <p style="padding-left: 20px;">Trouble Diagnosis with Starting/Charging System Tester (Charging)23</p> <p style="padding-left: 20px;">Power Generation Voltage Variable Control System Operation Inspection27</p> <p style="padding-left: 20px;">Removal and Installation28</p> <p style="padding-left: 20px;">Disassembly and Assembly32</p> <p>SERVICE DATA AND SPECIFICATIONS (SDS) 34</p> <p style="padding-left: 20px;">Battery34</p> <p style="padding-left: 20px;">Starter34</p> <p style="padding-left: 20px;">Alternator34</p>
--	---

A
B
C
D
E
F
G
H
I
J
K
L
M
N
O
P

SC

PRECAUTIONS

< SERVICE INFORMATION >

SERVICE INFORMATION

PRECAUTIONS

Precaution for Supplemental Restraint System (SRS) "AIR BAG" and "SEAT BELT PRE-TENSIONER"

INFOID:000000003389819

The Supplemental Restraint System such as "AIR BAG" and "SEAT BELT PRE-TENSIONER", used along with a front seat belt, helps to reduce the risk or severity of injury to the driver and front passenger for certain types of collision. This system includes seat belt switch inputs and dual stage front air bag modules. The SRS system uses the seat belt switches to determine the front air bag deployment, and may only deploy one front air bag, depending on the severity of a collision and whether the front occupants are belted or unbelted. Information necessary to service the system safely is included in the "SUPPLEMENTAL RESTRAINT SYSTEM" and "SEAT BELTS" of this Service Manual.

WARNING:

- To avoid rendering the SRS inoperative, which could increase the risk of personal injury or death in the event of a collision which would result in air bag inflation, all maintenance must be performed by an authorized NISSAN/INFINITI dealer.
- Improper maintenance, including incorrect removal and installation of the SRS, can lead to personal injury caused by unintentional activation of the system. For removal of Spiral Cable and Air Bag Module, see the "SUPPLEMENTAL RESTRAINT SYSTEM".
- Do not use electrical test equipment on any circuit related to the SRS unless instructed to in this Service Manual. SRS wiring harnesses can be identified by yellow and/or orange harnesses or harness connectors.

PRECAUTIONS WHEN USING POWER TOOLS (AIR OR ELECTRIC) AND HAMMERS

WARNING:

- When working near the Air Bag Diagnosis Sensor Unit or other Air Bag System sensors with the ignition ON or engine running, DO NOT use air or electric power tools or strike near the sensor(s) with a hammer. Heavy vibration could activate the sensor(s) and deploy the air bag(s), possibly causing serious injury.
- When using air or electric power tools or hammers, always switch the ignition OFF, disconnect the battery, and wait at least 3 minutes before performing any service.

Precaution for Power Generation Voltage Variable Control System

INFOID:000000002956638

CAUTION:

For this model, the battery current sensor that is installed to the battery cable at the negative terminal measures the charging/discharging current of the battery, and performs various controls. If the electrical component or the ground wire is connected directly to the battery terminal, the current other than that being measured with the battery current sensor is charging to or discharging from the battery. This condition causes the malfunction of the control, and then the battery discharge may occur. Do not connect the electrical component or the ground wire directly to the battery terminal.

PREPARATION

< SERVICE INFORMATION >

PREPARATION

Special Service Tool

INFOID:000000002956639

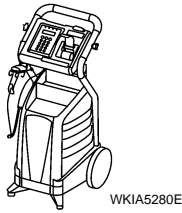
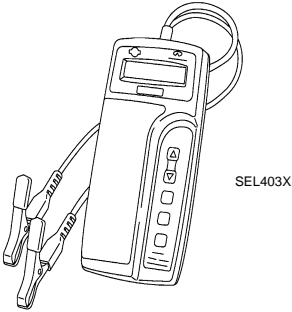
Tool number (Kent-Moore No.) Tool name	Description
<p>— (J-48087) Battery Service Center</p>  <p style="text-align: right; font-size: small;">WKIA5280E</p>	<p>Tests battery. For operating instructions, refer to Technical Service Bulletin and Battery Service Center User Guide.</p>
<p>— (J-44373 Model MCR620) Starting/Charging System Tester</p>  <p style="text-align: right; font-size: small;">SEL403X</p>	<p>Tests starting and charging systems. For operating instructions, refer to Technical Service Bulletin.</p>

Commercial Service Tool

INFOID:000000002956640

Tool name	Description
<p>Power tool</p>  <p style="text-align: right; font-size: small;">PIIB1407E</p>	<p>Loosening bolts, nuts and screws</p>

A
B
C
D
E
F
G
H
I
J
SC
L
M
N
O
P

BATTERY

< SERVICE INFORMATION >

BATTERY

How to Handle Battery

INFOID:000000002956641

CAUTION:

- If it becomes necessary to start the engine with a booster battery and jumper cables, use a 12-volt booster battery.
- After connecting battery cables, ensure that they are tightly clamped to battery terminals for good contact.
- Never add distilled water through the hole used to check specific gravity.

METHODS OF PREVENTING OVER-DISCHARGE

The following precautions must be taken to prevent over-discharging a battery.

- The battery surface (particularly its top) should always be kept clean and dry.
- The terminal connections should be clean and tight.
- At every routine maintenance, check the electrolyte level. This also applies to batteries designated as "low maintenance" and "maintenance-free".

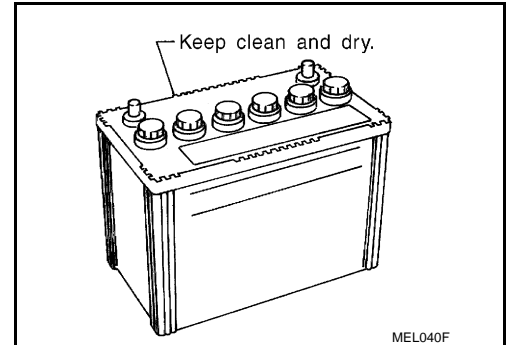

- When the vehicle is not going to be used over a long period of time, disconnect the battery cable from the negative terminal.

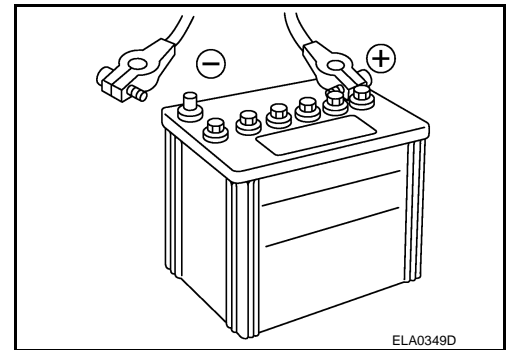

- Check the charge condition of the battery. Periodically check the specific gravity of the electrolyte. Keep a close check on charge condition to prevent over-discharge.

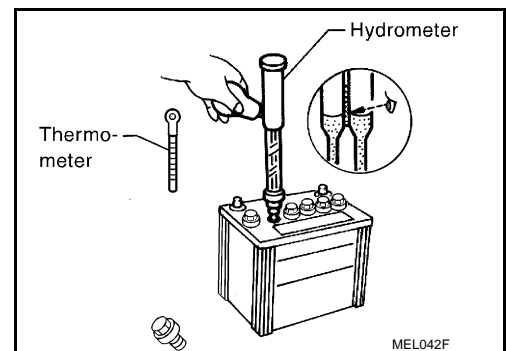

CHECKING ELECTROLYTE LEVEL

WARNING:

Never allow battery fluid to come in contact with skin, eyes, fabrics, or painted surfaces. After touching a battery, never touch or rub your eyes until you have thoroughly washed your hands. If acid contacts eyes, skin or clothing, immediately flush with water for 15 minutes and seek medical attention.

BATTERY

< SERVICE INFORMATION >

- Remove the cell plug using a suitable tool.
- Add distilled water up to the MAX level.

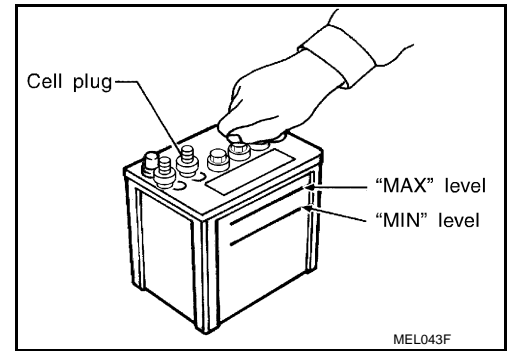

Sulphation

A battery will be completely discharged if it is left unattended for a long time and the specific gravity will become less than 1.100. This may result in sulphation on the cell plates.

To determine if a battery has been “sulphated”, note its voltage and current when charging it. As shown in the figure, less current and higher voltage are observed in the initial stage of charging sulphated batteries.

A sulphated battery may sometimes be brought back into service by means of a long, slow charge, 12 hours or more, followed by a battery capacity test.

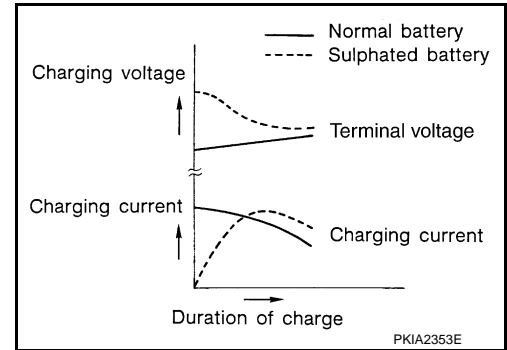

SPECIFIC GRAVITY CHECK

1. Read hydrometer and thermometer indications at eye level.
2. Use the chart below to correct your hydrometer reading according to electrolyte temperature.

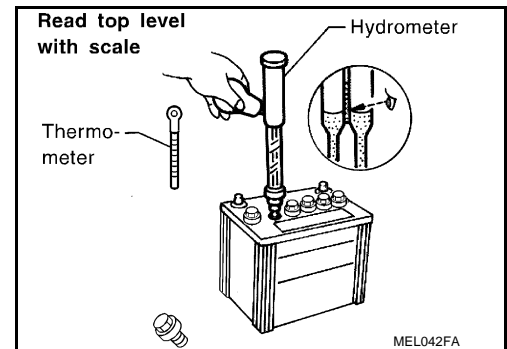

Hydrometer Temperature Correction

Battery electrolyte temperature °C (°F)	Add to specific gravity reading
71 (160)	0.032
66 (150)	0.028
60 (140)	0.024
54 (130)	0.020
49 (120)	0.016
43 (110)	0.012
38 (100)	0.008
32 (90)	0.004
27 (80)	0
21 (70)	-0.004
16 (60)	-0.008
10 (50)	-0.012
4 (40)	-0.016
-1 (30)	-0.020

BATTERY

< SERVICE INFORMATION >

Battery electrolyte temperature °C (°F)	Add to specific gravity reading
-7 (20)	-0.024
-12 (10)	-0.028
-18 (0)	-0.032

Corrected specific gravity	Approximate charge condition
1.260 - 1.280	Fully charged
1.230 - 1.250	3/4 charged
1.200 - 1.220	1/2 charged
1.170 - 1.190	1/4 charged
1.140 - 1.160	Almost discharged
1.110 - 1.130	Completely discharged

CHARGING THE BATTERY

CAUTION:

- Never “quick charge” a fully discharged battery.
- Keep the battery away from open flame while it is being charged.
- When connecting the charger, connect the leads first, then turn on the charger. Never turn on the charger first, as this may cause a spark.
- If battery electrolyte temperature rises above 55 °C (131 °F), stop charging. Always charge battery at a temperature below 55 °C (131 °F).

Charging Rates

Amps	Time
50	1 hour
25	2 hours
10	5 hours
5	10 hours

Never charge at more than 50 ampere rate.

NOTE:

The ammeter reading on your battery charger will automatically decrease as the battery charges. This indicates that the voltage of the battery is increasing normally as the state of charge improves. The charging amps indicated above refer to initial charge rate.

- If, after charging, the specific gravity of any two cells varies more than 0.050, the battery should be replaced.

Trouble Diagnosis with Battery Service Center

INFOID:000000002956642

For battery testing, use Battery Service Center (J-48087). For details and operating instructions, refer to Technical Service Bulletin and/or Battery Service Center User Guide.

Removal and Installation

INFOID:000000002956643

REMOVAL

1. Remove engine room cover RH.
2. Remove battery cover.

BATTERY

< SERVICE INFORMATION >

3. Remove the clips (A), and remove hoodledge cover RH (1).

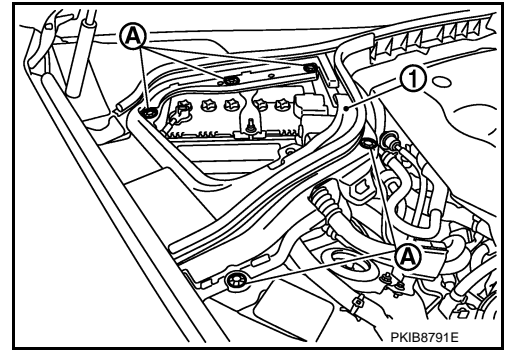

4. Remove the cowl top cover (RH). Refer to [EI-29, "Component Parts Location"](#).
5. Loosen battery terminal nuts (1), and disconnect both battery cables from battery terminals.

3 : Relay box

CAUTION:

When disconnecting, disconnect the battery cable from the negative terminal first.

6. Remove battery fix frame mounting nuts (2) and battery fix frame.
7. Remove battery.

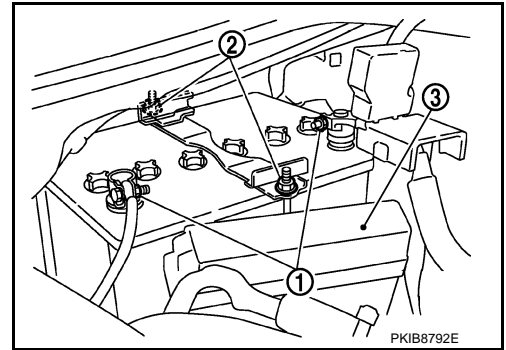

INSTALLATION

Installation is the reverse order of removal.

NOTE:

Locate the battery at the outside of the vehicle in the battery tray when installing the battery. Check that the positive terminal cap opens and closes.

CAUTION:

When connecting, connect the battery cable to the positive terminal first.

Battery fix frame mounting nut

: 4.4 N·m (0.45 kg·m, 39 in·lb)

Battery terminal nut

: 5.4 N·m (0.55 kg·m, 48 in·lb)

NOTE:

Reset electronic systems as necessary. Refer to [GI-53, "ADDITIONAL SERVICE WHEN REMOVING BATTERY NEGATIVE TERMINAL : Required Procedure After Battery Disconnection"](#).

STARTING SYSTEM

< SERVICE INFORMATION >

STARTING SYSTEM

System Description

INFOID:000000002956644

Power is supplied at all times

- through 15A fuse (No. 78, located in the IPDM E/R)
- to CPU of IPDM E/R,
- through 15A fuse (No. 71, located in the IPDM E/R)
- to CPU of IPDM E/R.

Ground is supplied

- to IPDM E/R terminals 38 and 51
- from grounds E22 and E43.

When the selector lever in the P or N position, power is supplied

- from TCM, and through A/T assembly terminal 9
- to IPDM E/R terminal 53.

And then provided that IPDM E/R receives a starter relay ON signal with CAN communication, starter relay is energized.

With the ignition switch in the START position, power is supplied

- through IPDM E/R terminal 3
- to starter motor terminal 1.

The starter motor plunger closes and provides a closed circuit between the battery and starter motor. The starter motor is grounded to the engine block. With power and ground supplied, cranking occurs and the engine starts.

STARTING SYSTEM

< SERVICE INFORMATION >

Wiring Diagram - START -

INFOID:00000002956645

VQ35DE ENGINE MODELS

SC-START-01

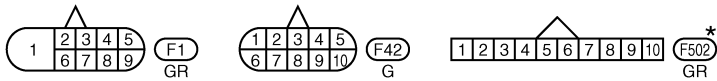
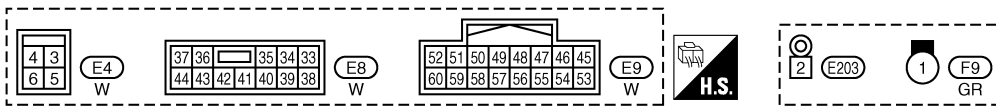
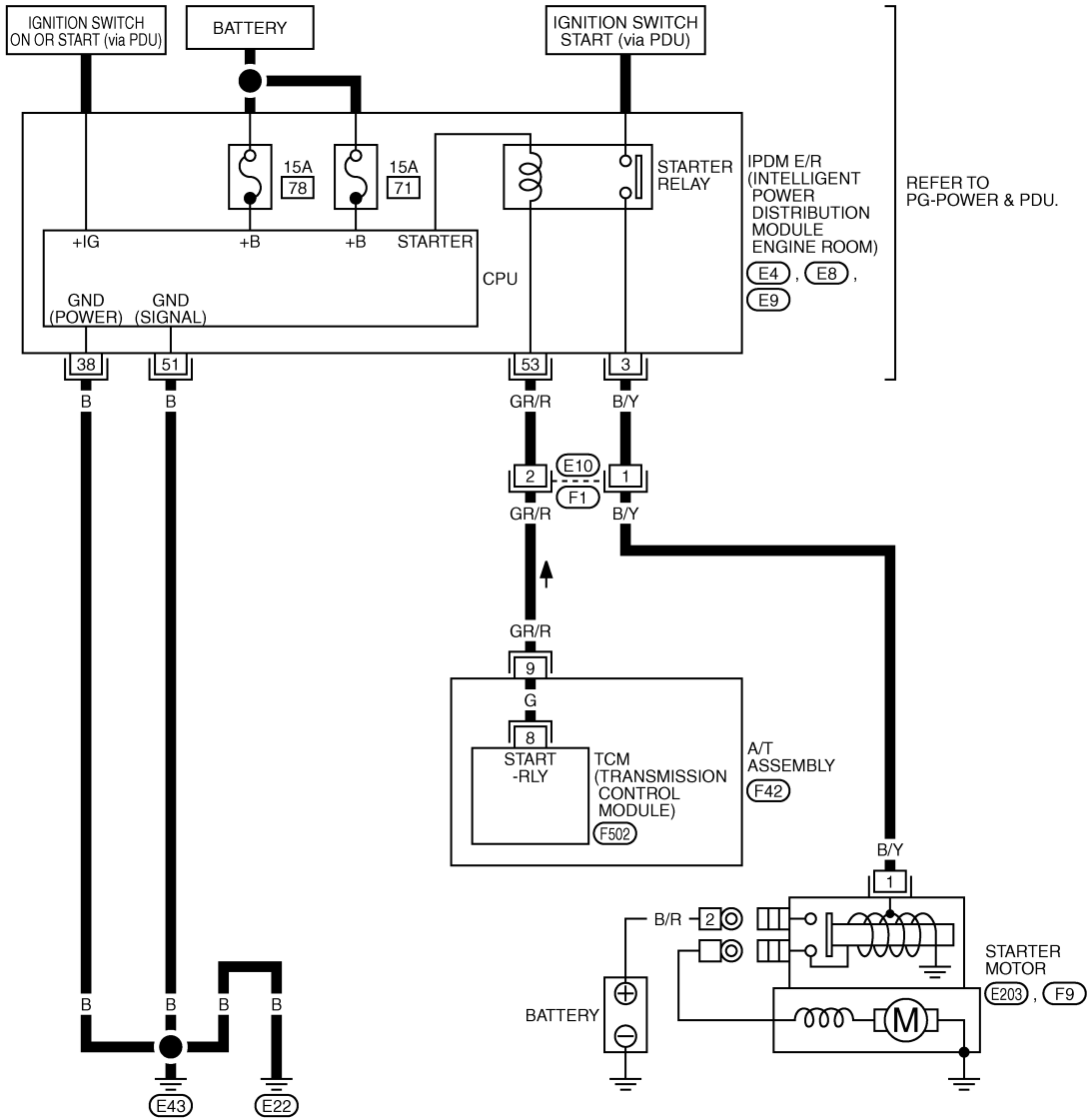

*: THIS CONNECTOR IS NOT SHOWN IN "HARNESS LAYOUT", PG SECTION.

TKWT3232E

STARTING SYSTEM

< SERVICE INFORMATION >

VK45DE ENGINE MODELS

SC-START-02

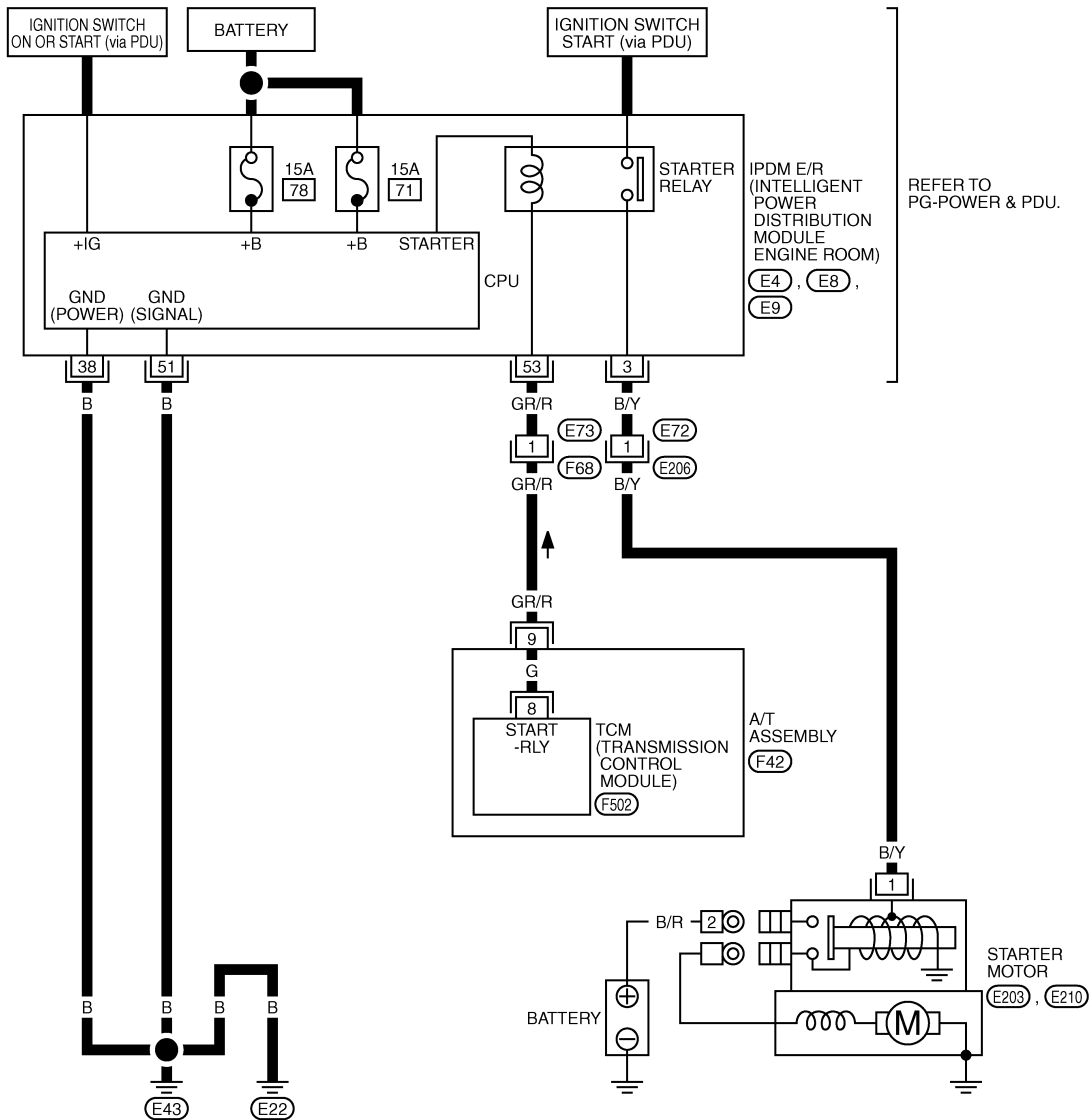

REFER TO PG-POWER & PDU.

IPDM E/R (INTELLIGENT POWER DISTRIBUTION MODULE ENGINE ROOM) (E4, E8, E9)

A/T ASSEMBLY (F42)

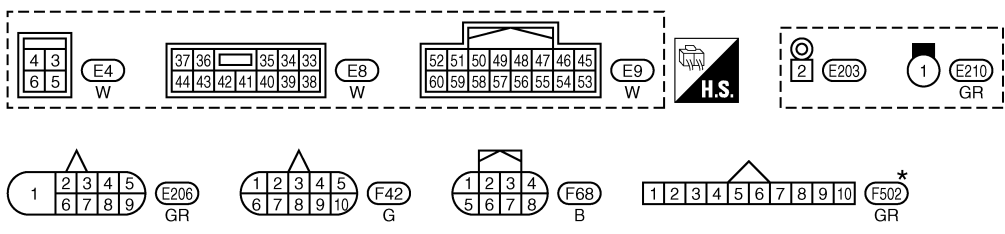

*: THIS CONNECTOR IS NOT SHOWN IN "HARNESS LAYOUT", PG SECTION.

TKWT3233E

Trouble Diagnosis with Starting/Charging System Tester (Starting)

INFOID:000000002956646

For starting system testing, use Starting/Charging System Tester (J-44373). For details and operating instructions, refer to Technical Service Bulletin.

STARTING SYSTEM

< SERVICE INFORMATION >

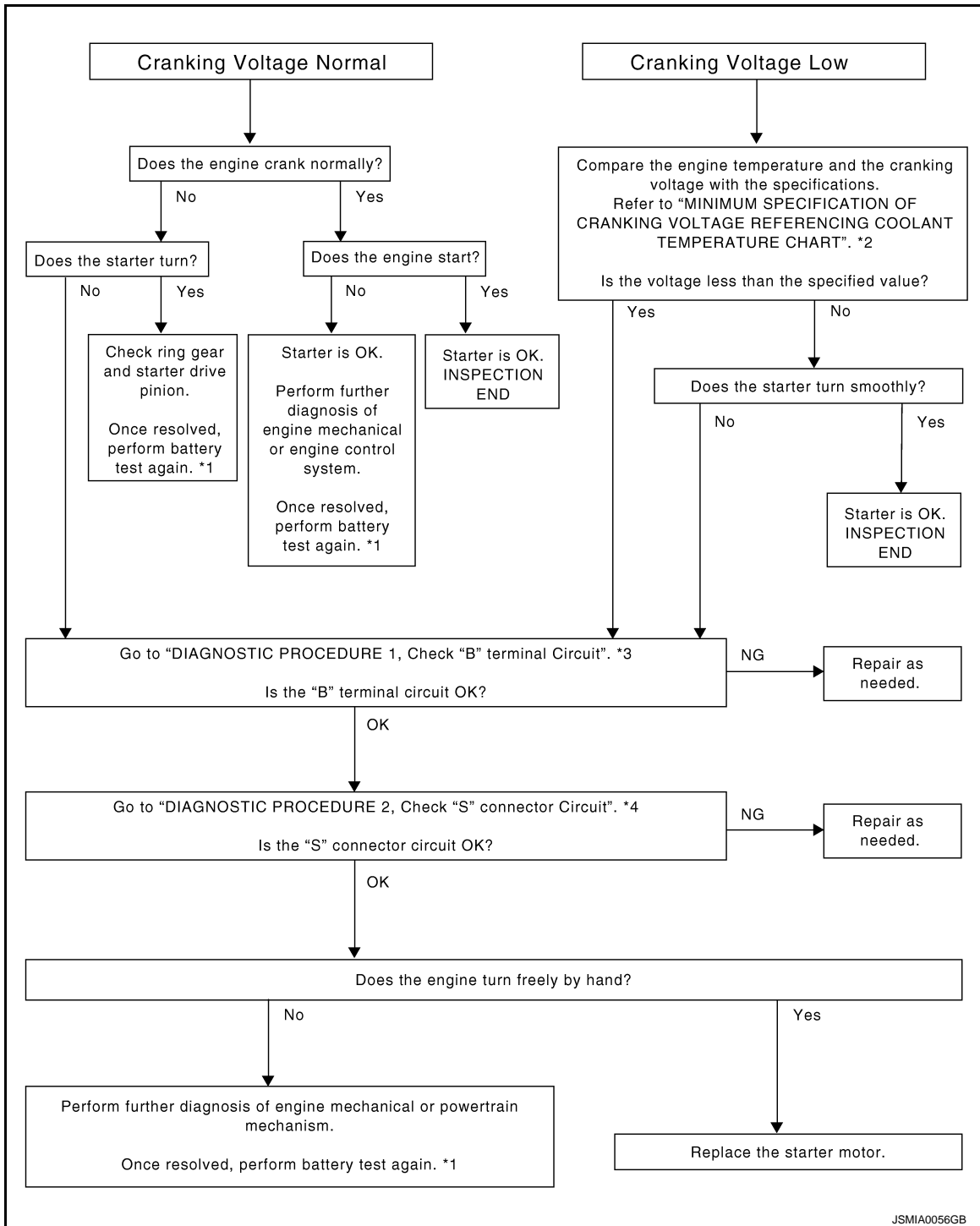

*1 For battery testing, use Battery Service Center (J-48087). For details and operating instructions, refer to Technical Service Bulletin and/or Battery Service Center User Guide.

*2 "MINIMUM SPECIFICATION OF CRANKING VOLTAGE REFERENCING COOLANT TEMPERATURE"

*3 "Check "B" Terminal Circuit"

*4 "Check "S" Connector Circuit"

DIAGNOSTIC PROCEDURE 1

Check "B" Terminal Circuit

CAUTION:

Perform diagnosis under the condition that engine cannot start by the following procedure.

1. Remove fuel pump fuse.

A
B
C
D
E
F
G
H
I
J
SC
L
M
N
O
P

STARTING SYSTEM

< SERVICE INFORMATION >

2. Crank or start the engine (where possible) until the fuel pressure is released.

1. CHECK "B" TERMINAL CIRCUIT

1. Turn ignition switch OFF.
2. Make sure that starter motor "B" terminal connection is clean and tight.
3. Check voltage between starter motor "B" terminal and ground.

Terminals		(-)	Voltage (Approx.)
(+)			
Starter motor "B" terminal	Terminal		
E203	2	Ground	Battery voltage

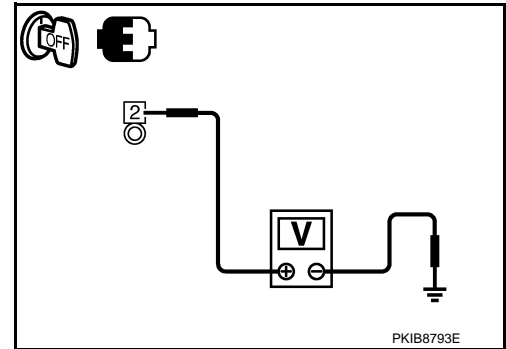

OK or NG

- OK >> GO TO 2.
 NG >> Check harness between battery and starter motor for open circuit.

2. CHECK BATTERY CABLE CONNECTION STATUS (VOLTAGE DROP TEST)

Check voltage between starter motor "B" terminal and battery positive terminal.

Terminals		Condition	Voltage (Approx.)
(+)	(-)		
	Starter motor "B" terminal		
Battery positive terminal	E203	2	When the ignition switch is in START position Less than 0.5 V

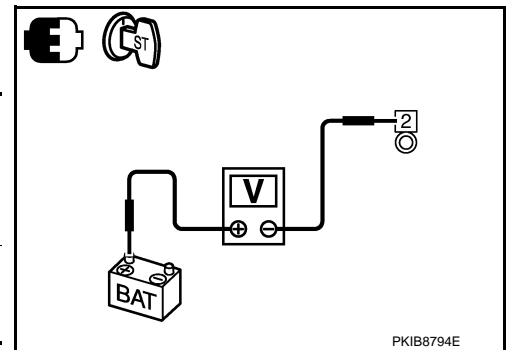

OK or NG

- OK >> GO TO 3.
 NG >> Check harness between the battery and the starter motor for poor continuity.

3. CHECK GROUND CIRCUIT STATUS (VOLTAGE DROP TEST)

1. Turn ignition switch OFF.
2. Check voltage between starter motor case and battery negative terminal.

Terminals		Condition	Voltage (Approx.)
(+)	(-)		
Starter motor case	Battery negative terminal	When the ignition switch is in START position	Less than 0.2 V

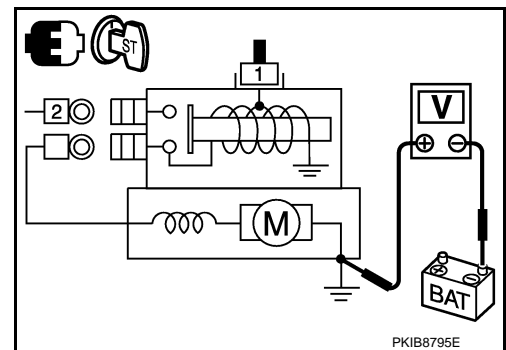

OK or NG

- OK >> "B" terminal circuit is OK. Further inspection necessary.
 Refer to "Trouble Diagnosis with Starting/Charging System Tester (Starting)".
 NG >> Check the starter motor case and ground for poor continuity.

DIAGNOSTIC PROCEDURE 2

Check "S" Connector Circuit

CAUTION:

Perform diagnosis under the condition that engine cannot start by the following procedure.

1. Remove fuel pump fuse.
2. Crank or start the engine (where possible) until the fuel pressure is released.

1. CHECK "S" CONNECTOR CIRCUIT

STARTING SYSTEM

< SERVICE INFORMATION >

1. Turn ignition switch OFF.
2. Disconnect starter motor connector.
3. Check voltage between starter motor harness connector and ground.

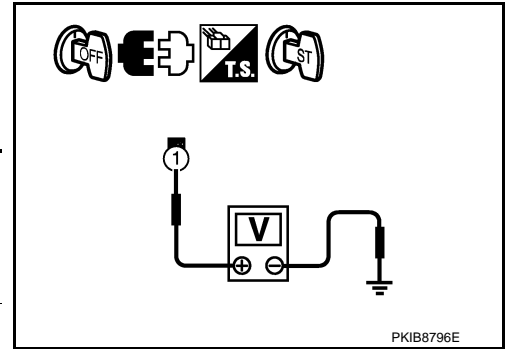

Terminals		(-)	Condition	Voltage (Approx.)
(+)	Terminal			
Starter motor connector				
F9 (VQ35DE) E210 (VK45DE)	1	Ground	When the ignition switch is in START position	Battery voltage

OK or NG

- OK >> "S" connector circuit is OK. Further inspection necessary. Refer to "Trouble Diagnosis with Starting/Charging System Tester (Starting)".
- NG >> Check the following.
- Ignition switch and PDU
 - IPDM E/R
 - Harness between starter motor and IPDM E/R

MINIMUM SPECIFICATION OF CRANKING VOLTAGE REFERENCING COOLANT TEMPERATURE

Engine coolant temperature	Voltage [V]
-30 °C to -20 °C (-22 °F to -4 °F)	8.6
-19 °C to -10 °C (-2 °F to 14°F)	9.1
-9 °C to 0 °C (16 °F to 32 °F)	9.5
More than 1 °C (More than 34 °F)	9.9

Removal and Installation

INFOID:000000002956647

VQ35DE ENGINE MODELS (2WD)

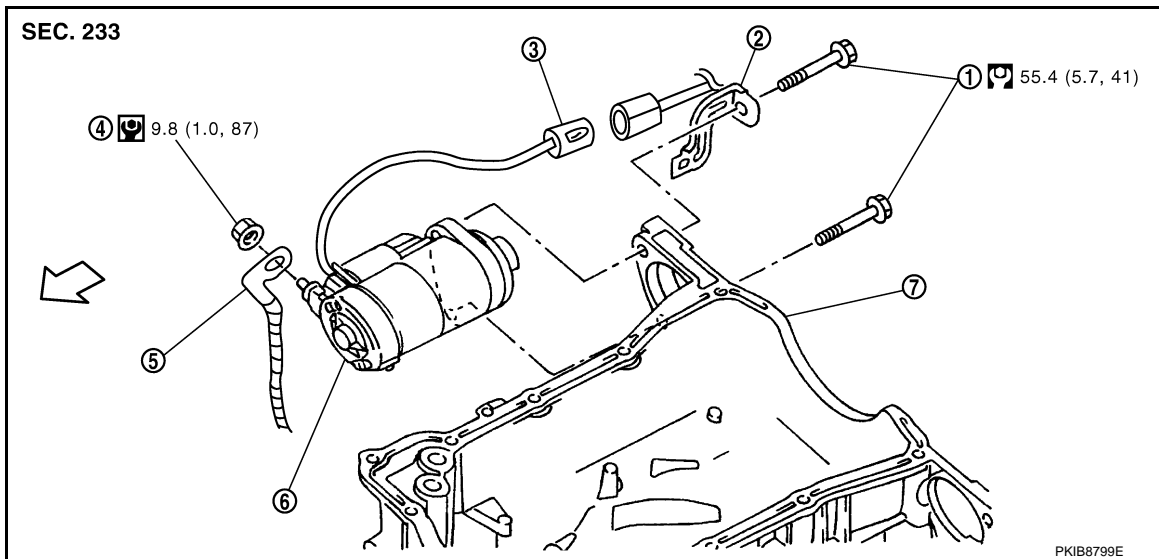

- | | | |
|--------------------------------|-------------------------|-----------------------|
| 1. Starter motor mounting bolt | 2. Harness clip bracket | 3. "S" connector |
| 4. "B" terminal nut | 5. "B" terminal harness | 6. Starter motor |
| 7. Oil pan | ⊗ : N·m (kg-m, ft-lb) | ⊗ : N·m (kg-m, in-lb) |

↶ : Engine front

STARTING SYSTEM

< SERVICE INFORMATION >

Removal

1. Disconnect the battery cable from the negative terminal.
2. Remove engine front and rear undercover, using power tools.
3. Remove "B" terminal nut (1).
4. Disconnect "S" connector (2).
5. Remove starter motor mounting bolts (A), using power tools.
6. Remove starter motor downward from the vehicle.

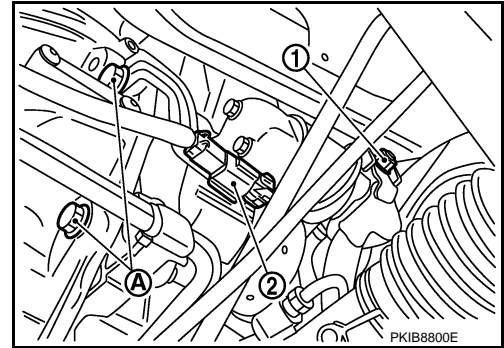

Installation

Installation is the reverse order of removal.

CAUTION:

Be sure to tighten "B" terminal nut carefully.

VQ35DE ENGINE MODELS (AWD)

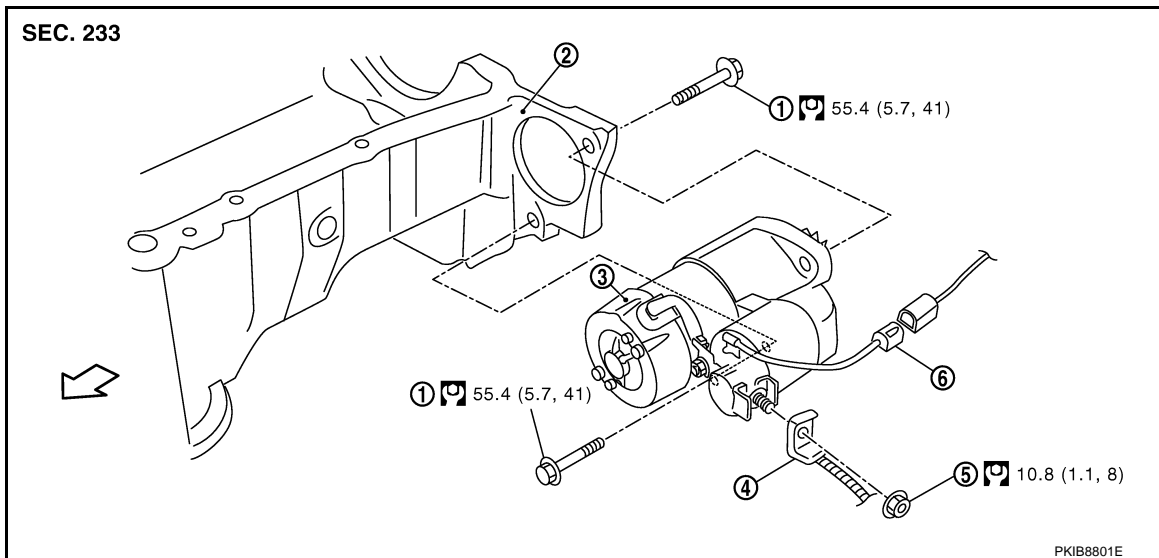

- | | | |
|--------------------------------|---------------------|------------------|
| 1. Starter motor mounting bolt | 2. Oil pan | 3. Starter motor |
| 4. "B" terminal harness | 5. "B" terminal nut | 6. "S" connector |

: N·m (kg-m, ft-lb)

: Engine front

Removal

1. Disconnect the battery cable from the negative terminal.
2. Remove engine rear undercover, using power tools.
3. Remove exhaust mounting bracket. Refer to [EM-27, "Removal and Installation"](#).

STARTING SYSTEM

< SERVICE INFORMATION >

4. Remove "B" terminal nut (1).

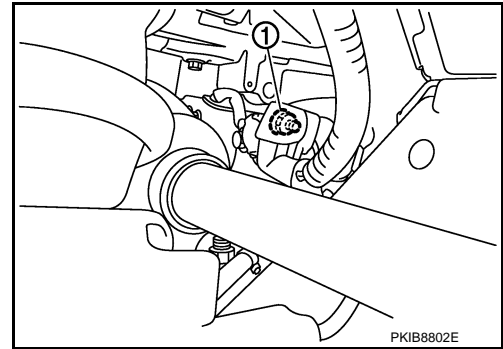

5. Disconnect "S" connector (1).

6. Remove starter motor mounting bolts (A) and harness bracket (2), using power tools.

7. Remove starter motor downward from the vehicle.

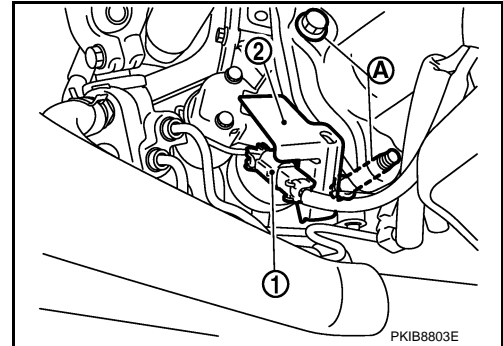

Installation

Installation is the reverse order of removal.

CAUTION:

Be sure to tighten "B" terminal nut carefully.

VK45DE ENGINE MODELS

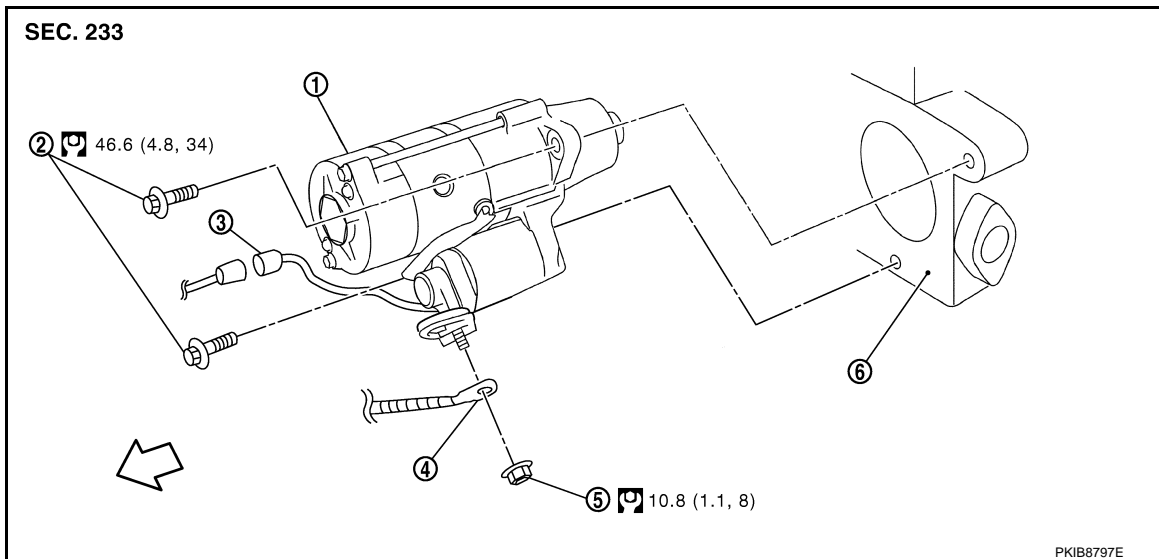

1. Starter motor

4. "B" terminal harness

: N-m (kg-m, ft-lb)

2. Starter motor mounting bolt

5. "B" terminal nut

: Engine front

3. "S" connector

6. Cylinder block

Removal

1. Disconnect the battery cable from the negative terminal.

STARTING SYSTEM

< SERVICE INFORMATION >

2. Remove engine front and rear undercover, using power tools.
3. Remove left engine mounting insulator and left engine mounting bracket. Refer to [EM-241](#).
4. Remove "B" terminal nut (1).
5. Disconnect "S" connector (2).
6. Remove the bolt (A) and the harness bracket (3).
7. Remove starter motor mounting bolts (B), using power tools.
8. Remove starter motor forward from the vehicle.

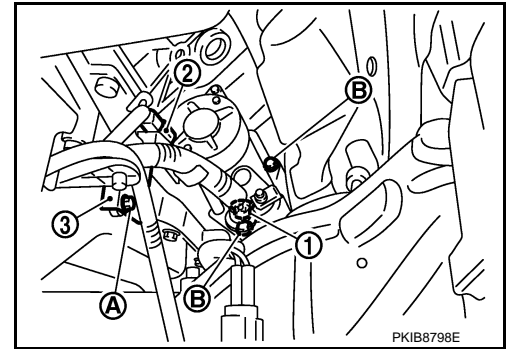

PKIB8798E

Installation

Installation is the reverse order of removal.

CAUTION:

Be sure to tighten "B" terminal nut carefully.

Disassembly and Assembly

INFOID:000000002956648

VQ35DE ENGINE MODELS (2WD)

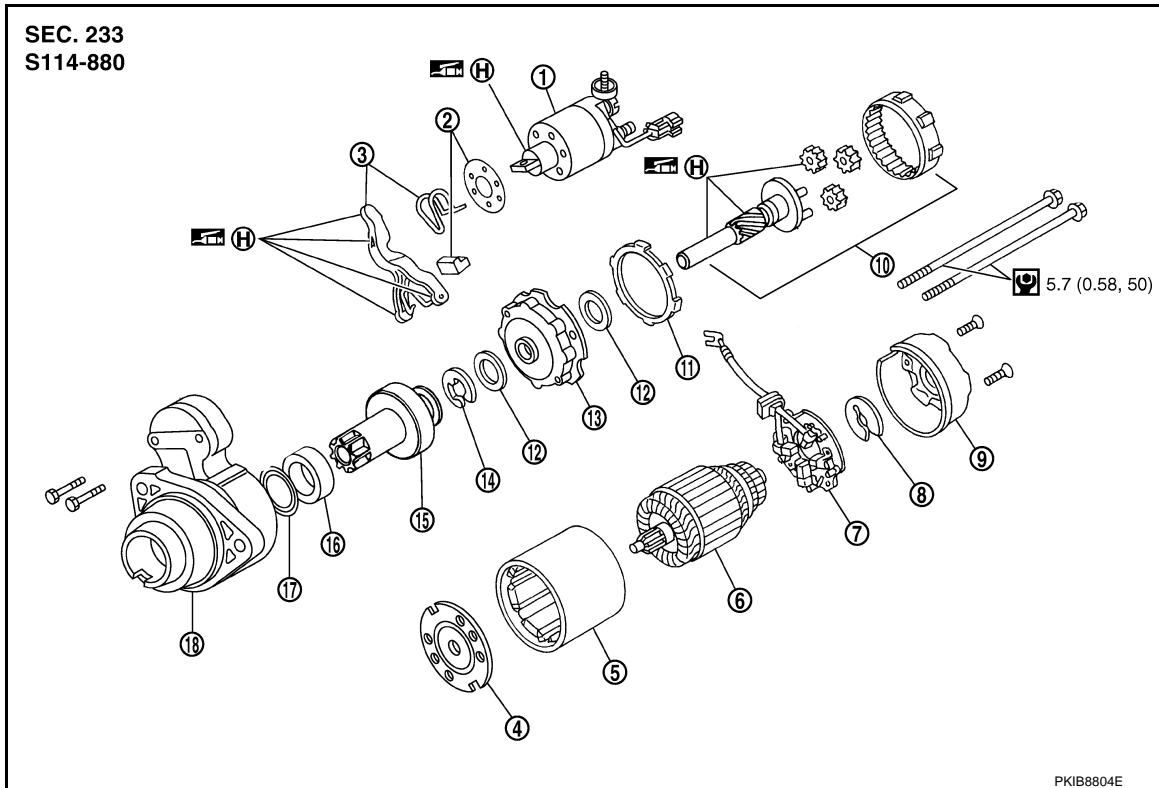

PKIB8804E

- | | | |
|-----------------------------|-------------------|------------------------|
| 1. Magnetic switch assembly | 2. Dust cover kit | 3. Shift lever set |
| 4. Center bracket (A) | 5. Yoke assembly | 6. Armature assembly |
| 7. Brush holder assembly | 8. Thrust washer | 9. Rear cover assembly |
| 10. Shaft gear assembly | 11. Packing | 12. Thrust washer |
| 13. Center bracket (P) | 14. E-ring | 15. Pinion assembly |
| 16. Ball bearing | 17. Caul | 18. Gear case assembly |

: N·m (kg-m, in-lb)

(H): High-temperature grease point

VQ35DE ENGINE MODELS (AWD)

STARTING SYSTEM

< SERVICE INFORMATION >

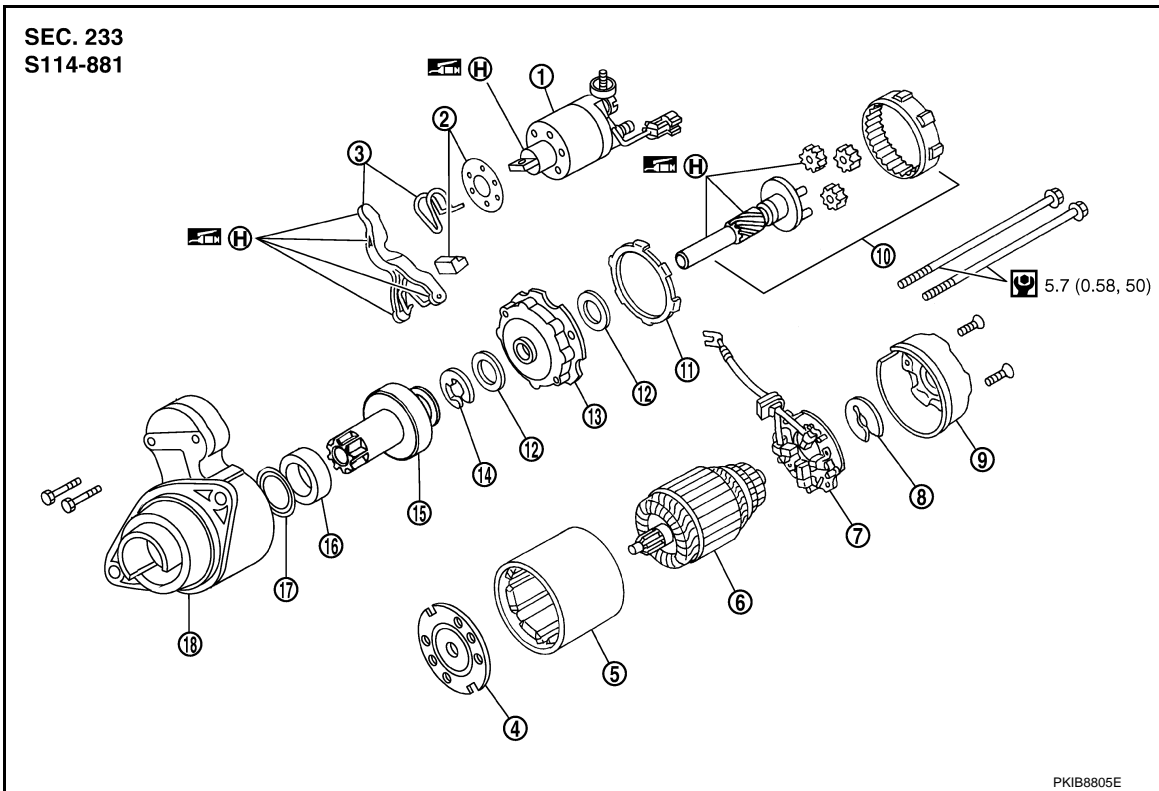

- | | | |
|-----------------------------|-------------------|------------------------|
| 1. Magnetic switch assembly | 2. Dust cover kit | 3. Shift lever set |
| 4. Center bracket (A) | 5. Yoke assembly | 6. Armature assembly |
| 7. Brush holder assembly | 8. Thrust washer | 9. Rear cover assembly |
| 10. Shaft gear assembly | 11. Packing | 12. Thrust washer |
| 13. Center bracket (P) | 14. E-ring | 15. Pinion assembly |
| 16. Ball bearing | 17. Caul | 18. Gear case assembly |
- : N-m (kg-m, in-lb)
 (H): High-temperature grease point

VK45DE ENGINE MODELS

A
B
C
D
E
F
G
H
I
J
L
M
N
O
P

SC

STARTING SYSTEM

< SERVICE INFORMATION >

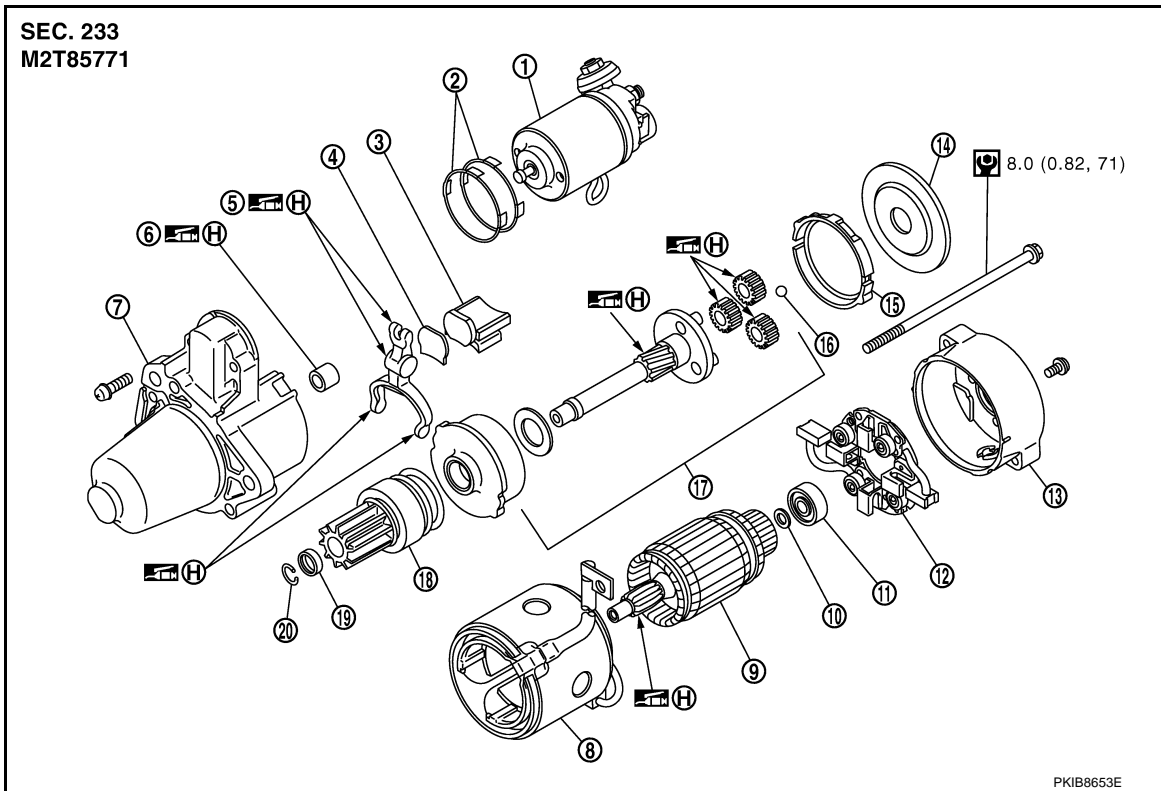

- | | | |
|-----------------------------|-------------------------|---------------------------|
| 1. Magnetic switch assembly | 2. Adjusting plate | 3. Packing |
| 4. Plate | 5. Shift lever | 6. Sleeve bearing |
| 7. Front bracket assembly | 8. Yoke assembly | 9. Armature assembly |
| 10. Washer | 11. Rear bearing | 12. Brush holder assembly |
| 13. Rear bracket assembly | 14. Cover | 15. Packing |
| 16. Ball | 17. Shaft gear assembly | 18. Clutch gear assembly |
| 19. Pinion stopper | 20. Stopper clip | |

 : N·m (kg·m, in·lb)

 (H): High-temperature grease point

Inspection After Disassembly

INFOID:000000002956649

PINION/CLUTCH CHECK

1. Inspect pinion teeth.
 - Replace pinion if teeth are worn or damaged. (Also check condition of ring gear teeth.)
2. Inspect reduction gear teeth.
 - Replace reduction gear if teeth are worn or damaged. (Also check condition of armature shaft gear teeth.)
3. Check if pinion locks in one direction and rotates smoothly in the opposite direction.
 - If it locks or rotates in both directions, or unusual resistance is evident, replace.

CHARGING SYSTEM

< SERVICE INFORMATION >

CHARGING SYSTEM

System Description

INFOID:00000002956650

DESCRIPTION

The alternator provides DC voltage to operate the vehicle's electrical system and to keep the battery charged. The voltage output is controlled by the IC regulator.

Power is supplied at all times

- through 10A fuse [No. 36, located in the fuse, fusible link and relay block (J/B)]
- to alternator terminal 4 ("S" terminal).

"B" terminal supplies power to charge the battery and operate the vehicle's electrical system. Output voltage is controlled by the IC regulator at terminal 4 ("S" terminal) detecting the input voltage.

The alternator is grounded to the engine block.

With the ignition switch in the ON or START position, power is supplied

- through 10A fuse [No. 14, located in the fuse block (J/B)]
- to combination meter terminal 12 for the charge warning lamp.

Ground is supplied at signal

- to combination meter terminal 22
- through alternator terminal 3 ("L" terminal).

Then power and ground are supplied, the charge warning lamp will illuminate.

When the alternator is providing sufficient voltage with the engine running, the ground is opened and the charge warning lamp will go off.

If the charge warning lamp illuminates with the engine running, a malfunction is indicated.

Ground is supplied

- to alternator terminal 2 ("E" terminal)
- through grounds E222, E223 and E224. (VQ35DE)
- through ground E212. (VK45DE)

MALFUNCTION INDICATOR

The IC regulator warning function activates to illuminate the charge warning lamp, if any of the following symptoms occur while alternator is operating:

- Excessive voltage is produced.
- No voltage is produced.

POWER GENERATION VOLTAGE VARIABLE CONTROL SYSTEM

Power generation voltage variable control system that controls the power generation voltage of the alternator has been adopted. By performing the power generation voltage variable control, the engine load due to the power generation of the alternator is reduced and fuel consumption is decreased.

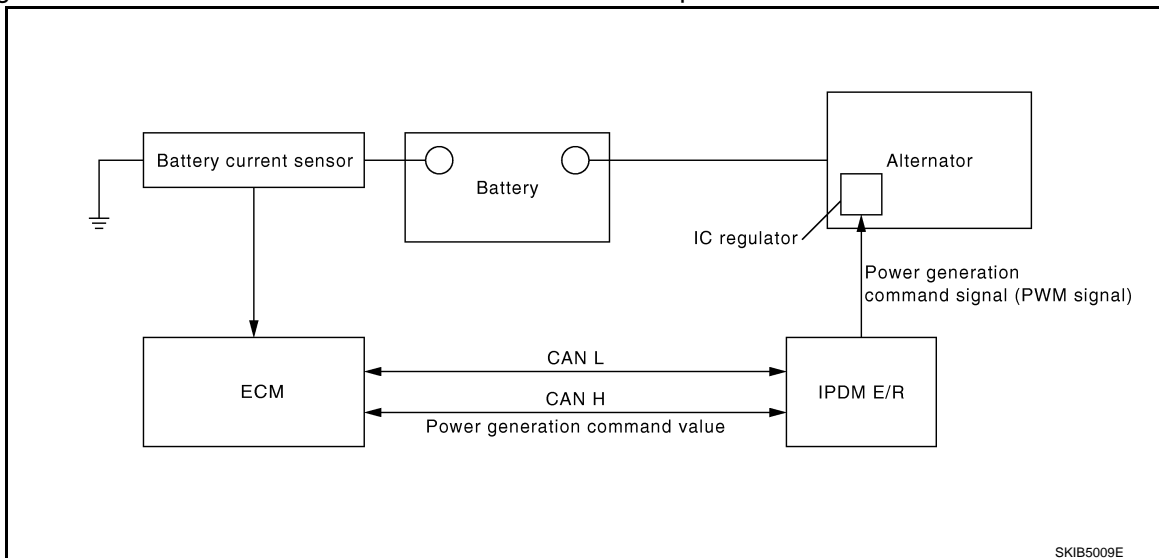

Operation Description

- The battery current sensor detects the charging/discharging current of the battery. ECM judges the battery condition based on this signal.

CHARGING SYSTEM

< SERVICE INFORMATION >

- ECM judges whether to perform the power generation voltage variable control according to the battery condition.
- When performing the power generation voltage variable control, ECM calculates the target power generation voltage according to the battery condition and sends the calculated value as the power generation command value to IPDM E/R.
- IPDM E/R converts the received power generation command value into the power generation command signal (PWM signal) and sends it to the IC regulator.
- The IC regulator controls the power generation voltage by the target power generation voltage based on the received power generation command signal.
- When there is no power generation command signal, the alternator performs the normal power generation according to the characteristic of the IC regulator.

NOTE:

When any malfunction is detected in the power generation voltage variable control system, the power generation is performed according to the characteristic of the IC regulator of the alternator.

Main Component Part

BATTERY CURRENT SENSOR

- Battery current sensor (1) is installed to the battery cable at the negative terminal, and it detects the charging/discharging current of the battery and sends the voltage signal to ECM according to the current value.

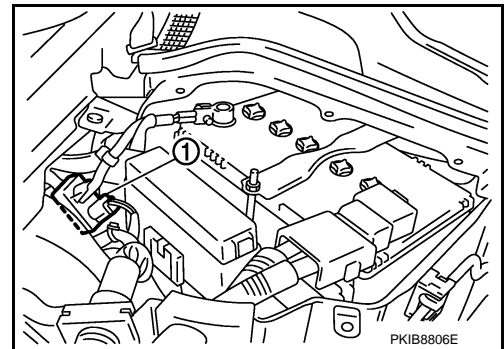

CHARGING SYSTEM

< SERVICE INFORMATION >

Wiring Diagram - CHARGE -

INFOID:00000002956651

VQ35DE ENGINE MODELS (2WD)

SC-CHARGE-01

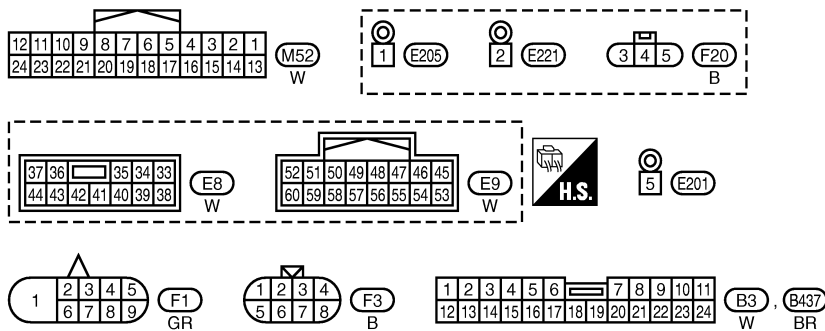
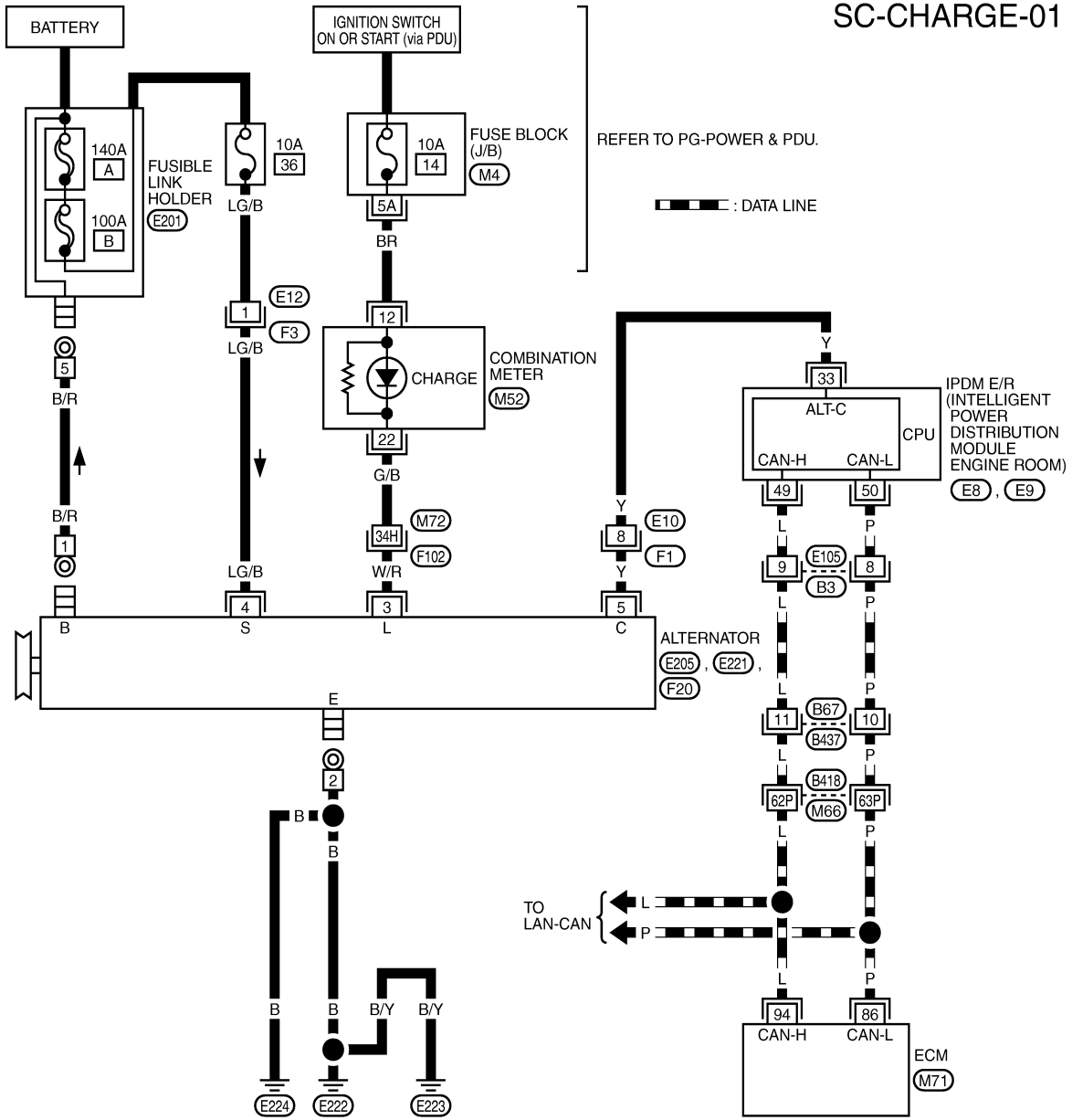

TKWT6793E

CHARGING SYSTEM

< SERVICE INFORMATION >

VQ35DE ENGINE MODELS (AWD)

SC-CHARGE-02

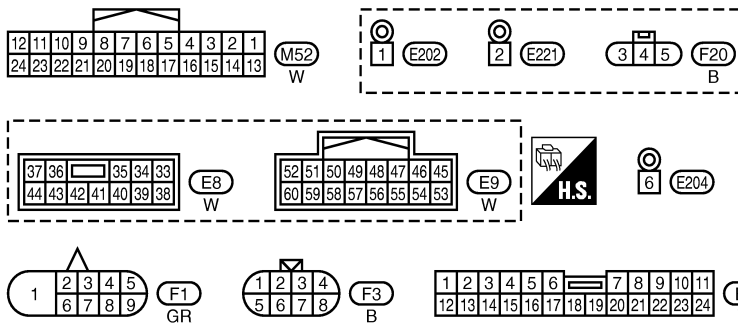
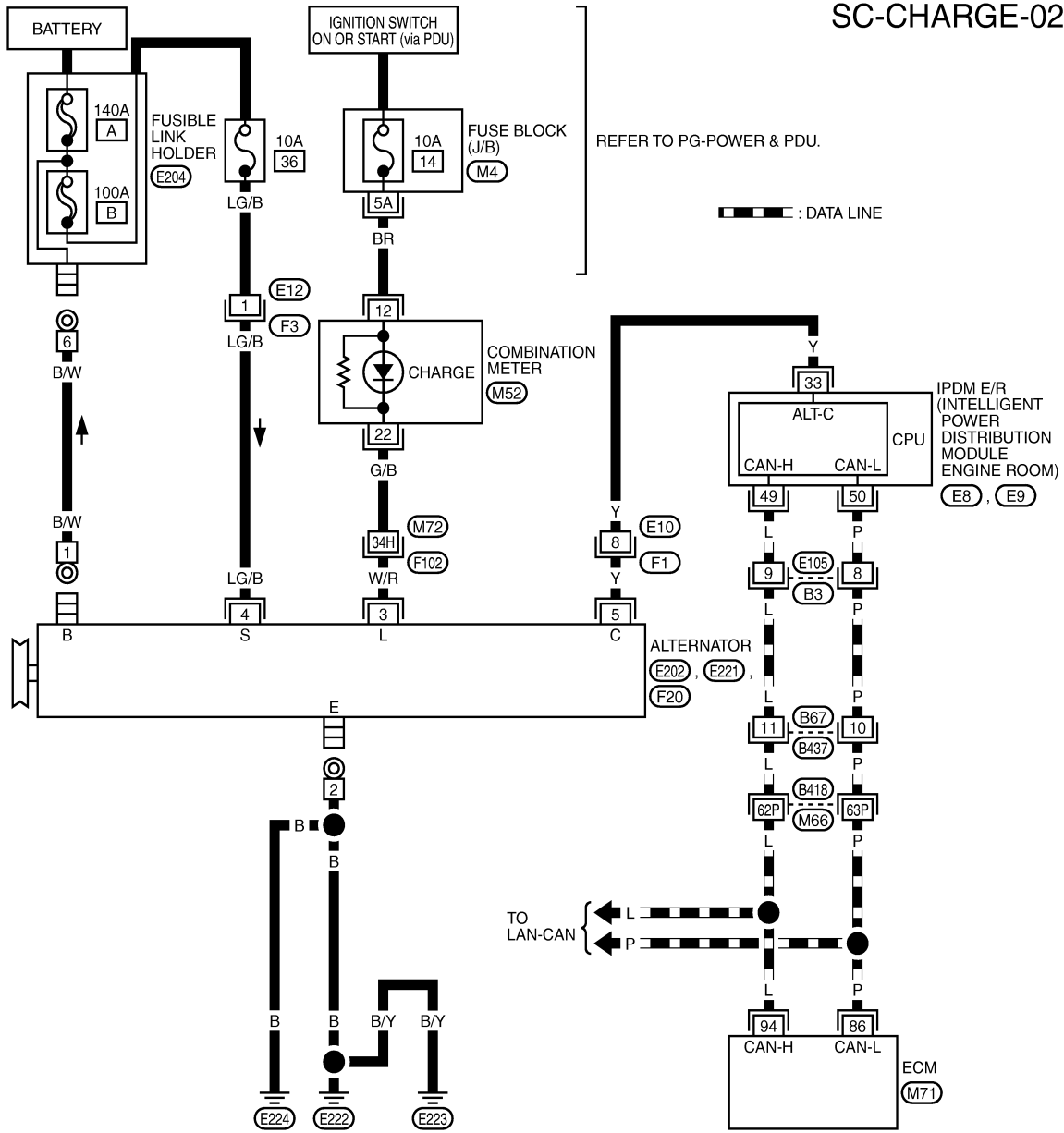

REFER TO THE FOLLOWING.

- (F102), (B418) - SUPER MULTIPLE JUNCTION (SMJ)
- (M4) - FUSE BLOCK - JUNCTION BOX (J/B)
- (M71) - ELECTRICAL UNITS

TKWT6794E

CHARGING SYSTEM

< SERVICE INFORMATION >

VK45DE ENGINE MODELS

SC-CHARGE-03

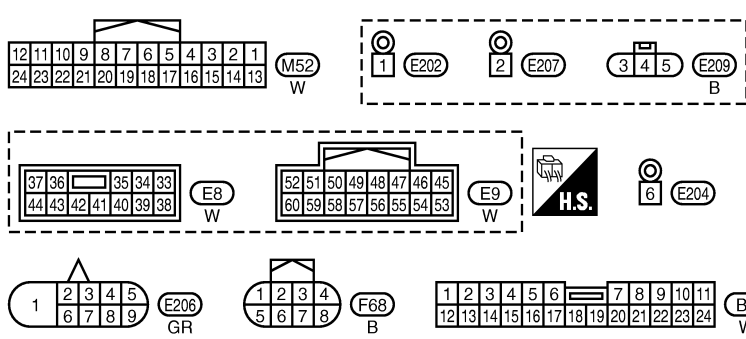
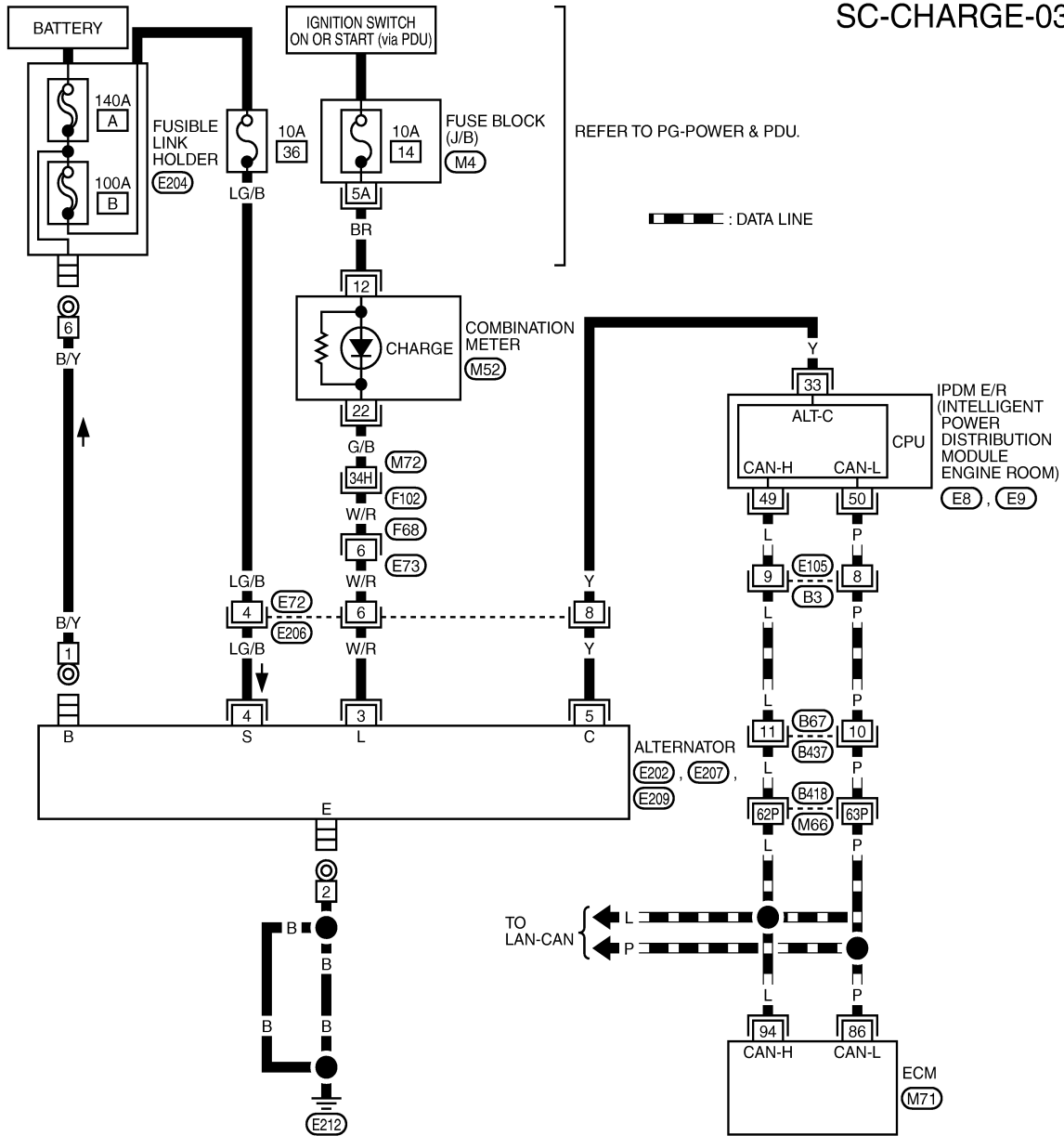

REFER TO THE FOLLOWING.
 (F102, B418) - SUPER MULTIPLE JUNCTION (SMJ)
 (M4) - FUSE BLOCK - JUNCTION BOX (J/B)
 (M71) - ELECTRICAL UNITS

TKWT6795E

Trouble Diagnosis with Starting/Charging System Tester (Charging)

INFOID:000000002956652

For charging system testing, use Starting/Charging System Tester (J-44373). For details and operating instructions, refer to Technical Service Bulletin.

CHARGING SYSTEM

< SERVICE INFORMATION >

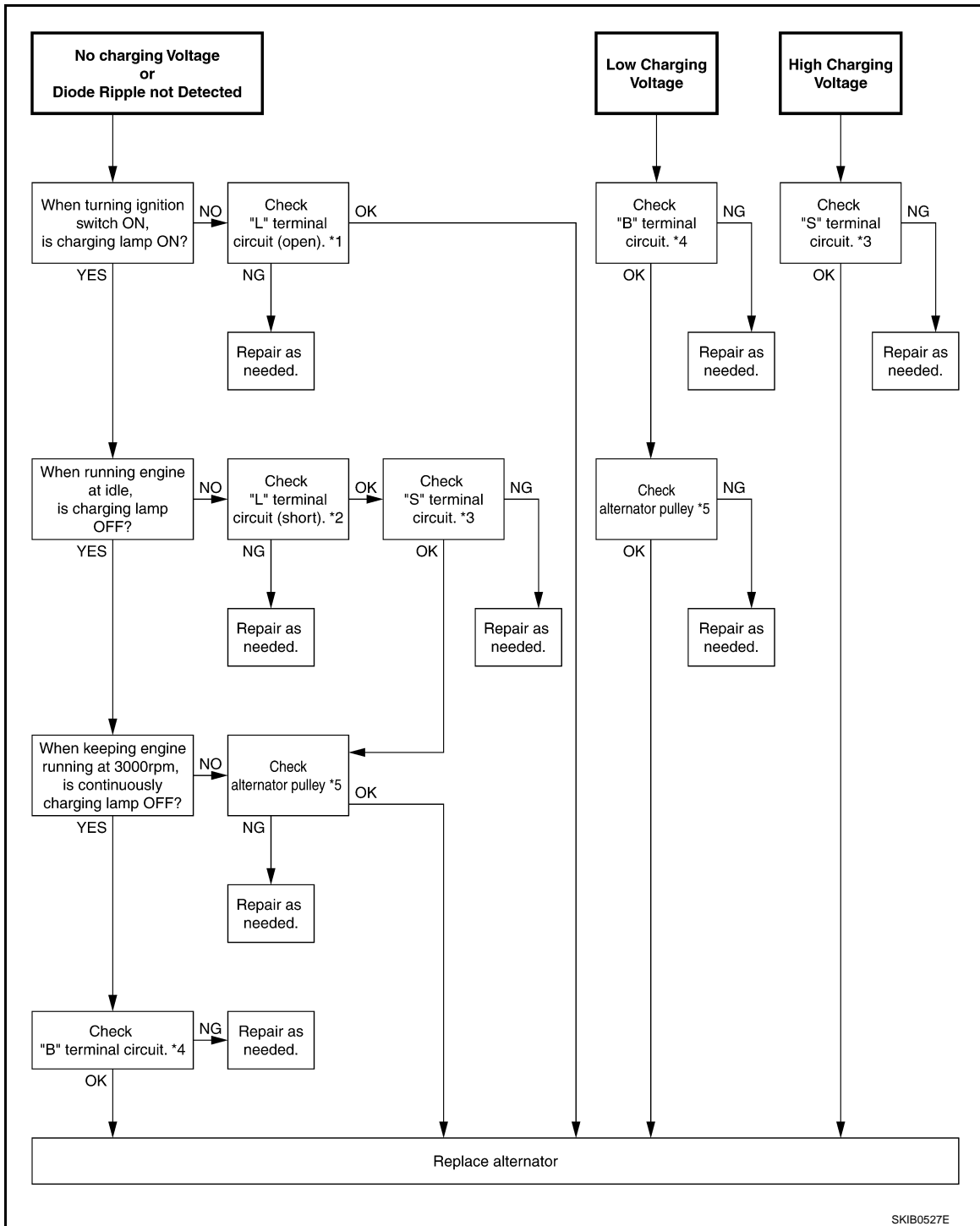

SKIB0527E

- *1 "Check "L" Terminal Circuit (Open)" *2 "Check "L" Terminal Circuit (Short)" *3 "Check "S" Terminal Circuit"
 *4 "Check "B" Terminal Circuit" *5 [SC-28. "Removal and Installation" \(VQ35DE\)](#)
[SC-28. "Removal and Installation" \(VK45DE\)](#)

PRELIMINARY INSPECTION

1. CHECK BATTERY TERMINALS CONNECTION

Check if battery terminals is clean and tight.

OK or NG

OK >> GO TO 2.

CHARGING SYSTEM

< SERVICE INFORMATION >

NG >> Repair battery terminals connection.

2.CHECK FUSE AND FUSIBLE LINK

Check for blown fuse and fusible link.

Unit	Power source (Power supply terminals)	Fuse and fusible link No.
Alternator	Battery ("S" terminal)	36
Combination meter	Ignition switch ON ("L" terminal)	14

OK or NG

OK >> GO TO 3.

NG >> If fuse is blown, be sure to eliminate cause of malfunction before installing new fuse.

3.CHECK "E" TERMINAL CONNECTION

Check if "E" terminal (alternator ground harness) is clean and tight.

OK or NG

OK >> GO TO 4.

NG >> Repair "E" terminal connection.

4.CHECK ALTERNATOR DRIVE BELT TENSION

Check alternator drive belt tension. Refer to the following.

- VQ35DE: [EM-17, "Removal and Installation"](#)
- VK45DE: [EM-172, "Removal and Installation"](#)

OK or NG

OK >> INSPECTION END

NG >> Repair as needed.

DIAGNOSTIC PROCEDURE 1

Check "L" Terminal Circuit (Open)

1.CHECK "L" TERMINAL CONNECTION

1. Turn ignition switch OFF.
2. Check if "L" terminal is clean and tight.

OK or NG

OK >> GO TO 2.

NG >> Repair "L" terminal connection. Confirm repair by performing complete Starting/Charging system test. Refer to Technical Service Bulletin.

2.CHECK "L" TERMINAL CIRCUIT (OPEN)

1. Disconnect alternator connector.
2. Apply ground to alternator harness connector terminal.
3. Check condition the charge warning lamp with the ignition switch in the ON position.

Alternator connector	Terminal	Ground	Condition	
			Ignition switch position	Charge warning lamp
F20 (VQ35DE) E209 (VK45DE)	3		ON	illuminate

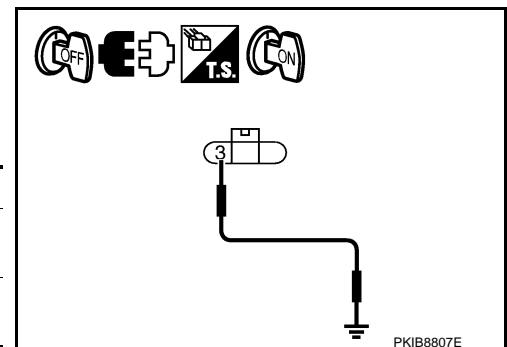

OK or NG

OK >> Go to "Trouble Diagnosis with Starting/Charging System Tester (Charging)".

NG >> Check the following.

- Harness for open between combination meter and alternator
- Harness for open between combination meter and fuse
- Charge warning lamp (Combination meter)

DIAGNOSTIC PROCEDURE 2

CHARGING SYSTEM

< SERVICE INFORMATION >

Check "L" Terminal Circuit (Short)

1.CHECK "L" TERMINAL CIRCUIT (SHORT)

1. Turn ignition switch OFF.
2. Disconnect alternator connector.
3. Turn ignition switch ON.

Charge warning lamp should illuminate?

YES >> Check the following.

- Harness for short between combination meter and alternator
- Charge warning lamp (Combination meter)

NO >> Go to "Trouble Diagnosis with Starting/Charging System Tester (Charging)".

DIAGNOSTIC PROCEDURE 3

Check "S" Terminal Circuit

1.CHECK "S" TERMINAL CONNECTION

1. Turn ignition switch OFF.
2. Check if "S" terminal is clean and tight.

OK or NG

OK >> GO TO 2.

NG >> Repair "S" terminal connection. Confirm repair by performing complete Starting/Charging system test. Refer to Technical Service Bulletin.

2.CHECK "S" TERMINAL CIRCUIT

1. Disconnect alternator connector.
2. Check voltage between alternator harness connector and ground.

Terminals		(-)	Voltage (Approx.)
(+)			
Alternator connector	Terminal	Ground	Battery voltage
F20 (VQ35DE) E209 (VK45DE)	4		

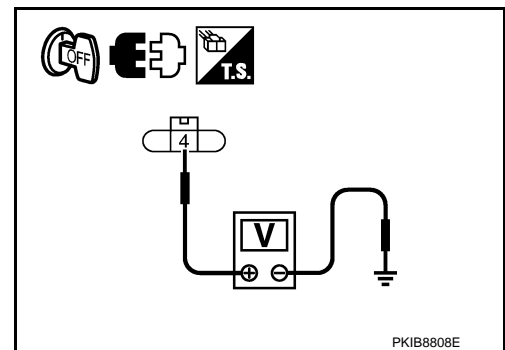

OK or NG

OK >> Go to "Trouble Diagnosis with Starting/Charging System Tester (Charging)".

NG >> Check harness for open between alternator and fuse.

DIAGNOSTIC PROCEDURE 4

Check "B" Terminal Circuit

1.CHECK "B" TERMINAL CONNECTION

1. Turn ignition switch OFF.
2. Check if "B" terminal is clean and tight.

OK or NG

OK >> GO TO 2.

NG >> Repair "B" terminal connection. Confirm repair by performing complete Starting/Charging system test. Refer to Technical Service Bulletin.

2.CHECK "B" TERMINAL CIRCUIT

CHARGING SYSTEM

< SERVICE INFORMATION >

Check voltage between alternator "B" terminal and ground.

Terminals			Voltage (Approx.)
(+)		(-)	
Alternator "B" terminal	Terminal		
E205 [VQ35DE (2WD)] E202 [VQ35DE (AWD)/VK45DE]	1	Ground	Battery voltage

OK or NG

- OK >> GO TO 3.
 NG >> Check harness for open between alternator and fusible link.

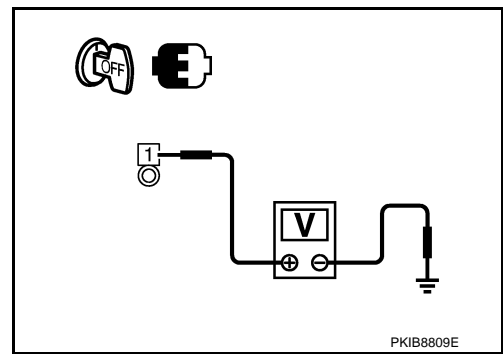

3. CHECK "B" TERMINAL CONNECTION (VOLTAGE DROP TEST)

- Start engine, then engine running at idle and warm.
- Check voltage between battery positive terminal and alternator "B" terminal.

Terminals			Voltage (Approx.)
(+)	(-)		
	Battery positive terminal	Alternator "B" terminal	Terminal
	E205 [VQ35DE (2WD)] E202 [VQ35DE (AWD)/VK45DE]	1	Less than 0.2 V

OK or NG

- OK >> Go to "Trouble Diagnosis with Starting/Charging System Tester (Charging)".
 NG >> Check harness between battery and alternator for poor continuity.

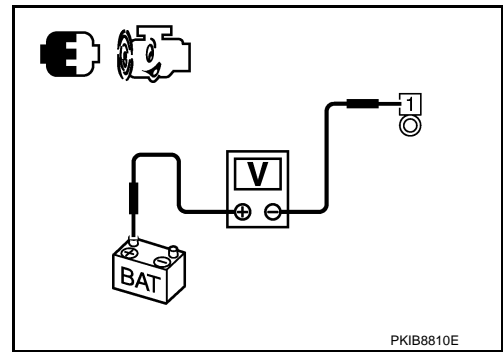

Power Generation Voltage Variable Control System Operation Inspection

INFOID:000000002956653

CAUTION:

- For this model, the battery current sensor that is installed to the battery cable at the negative terminal measures the charging/discharging current of the battery, and performs various controls. If the electrical component or the ground wire is connected directly to the battery terminal, the current other than that being measured with the battery current sensor is charging to or discharging from the battery. This condition causes the malfunction of the control, and then the battery discharge may occur. Never connect the electrical component or the ground wire directly to the battery terminal.
- When performing this inspection, always use the charged battery that completed the battery inspection. (When the charging rate of the battery is low, the response speed of the voltage change will become slow. This is a cause of an incorrect inspection.)

INSPECTION PROCEDURE

1. CHECK ECM (CONSULT-III)

Perform ECM self-diagnosis with CONSULT-III. Refer to the following.

- VQ35DE: [EC-116, "CONSULT-III Function \(ENGINE\)"](#)
- VK45DE: [EC-741, "CONSULT-III Function"](#)

Self-diagnostic results content

No malfunction detected>> GO TO 2.

Malfunction detected>> Check applicable parts, and repair or replace corresponding parts.

2. CHECK OPERATION OF POWER GENERATION VOLTAGE VARIABLE CONTROL SYSTEM

- Connect CONSULT-III and start the engine.
- The selector lever is in "P" or "N" position and all of the electric loads and A/C, etc. are turned OFF.
- Select "ALTERNATOR DUTY" at "ACTIVE TEST" of "ENGINE", and then check the value of "BATTERY VOLT" monitor when DUTY value of "ALTERNATOR DUTY" is set to 40.0 %.

CHARGING SYSTEM

< SERVICE INFORMATION >

“BATTERY VOLT”

2 seconds after setting the : 12 - 13.6 V
DUTY value of “ALTERNATOR DUTY” to 40.0 %

- Check the value of “BATTERY VOLT” monitor when DUTY value of “ALTERNATOR DUTY” is set to 80.0%.

“BATTERY VOLT”

20 seconds after setting : +0.5 V or more against
the DUTY value of “ALTERNATOR DUTY” to 80.0 % the value of “BATTERY VOLT” monitor when
DUTY value is 40.0 %

OK or NG

- OK >> INSPECTION END
NG >> GO TO 3. (The charging condition of the battery should be normal.)

3. CHECK IPDM E/R (CONSULT-III)

Perform IPDM E/R self-diagnosis with CONSULT-III. Refer to [PG-20, "CONSULT-III Function \(IPDM E/R\)".](#)

Self-diagnostic results content

- No malfunction detected>> GO TO 4.
Malfunction detected>> Check applicable parts, and repair or replace corresponding parts.

4. CHECK HARNESS BETWEEN ALTERNATOR AND IPDM E/R

- Turn ignition switch OFF.
- Disconnect alternator connector and IPDM E/R connector.
- Check continuity between alternator harness connector (A) and IPDM E/R harness connector (B).

A		B		Continuity
Connector	Terminal	Connector	Terminal	
F20 (VQ35DE) E209 (VK45DE)	5	E8	33	Yes

- Check continuity between alternator harness connector (A) and ground.

A		Ground	Condition
Connector	Terminal		
F20 (VQ35DE) E209 (VK45DE)	5		No

OK or NG

- OK >> Replace IPDM E/R.
NG >> Repair harness or connector between IPDM E/R and alternator.

Removal and Installation

INFOID:00000002956654

VQ35DE ENGINE MODELS

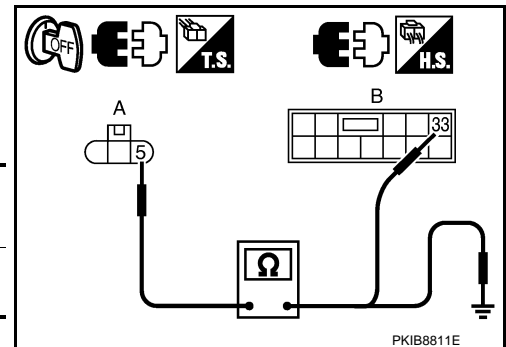

CHARGING SYSTEM

< SERVICE INFORMATION >

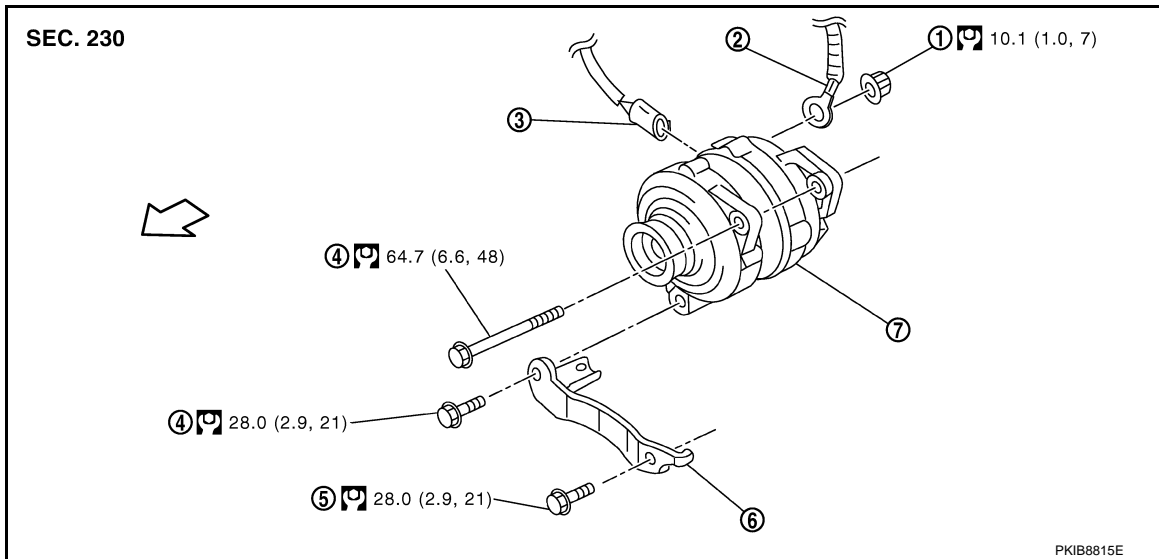

- | | | |
|-----------------------------|----------------------------------|-------------------------|
| 1. "B" terminal nut | 2. "B" terminal harness | 3. Alternator connector |
| 4. Alternator mounting bolt | 5. Alternator stay mounting bolt | 6. Alternator stay |
| 7. Alternator | Ⓜ : N·m (kg·m, ft·lb) | ↔ : Engine front |

Removal (2WD Models)

1. Disconnect the battery cable from the negative terminal.
2. Remove engine front undercover, using power tools.
3. Remove alternator and power steering oil pump belt. Refer to [EM-15](#).
4. Disconnect alternator connector (1).
5. Remove "B" terminal nut (2).
6. Remove the harness bracket bolts (A).

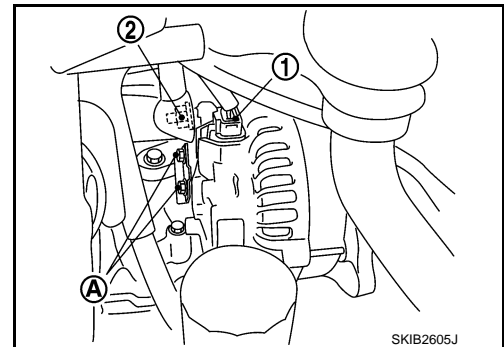

7. Remove oil pressure switch harness clip (A) from alternator stay.
8. Disconnect oil pressure switch connector (1).
9. Remove alternator mounting bolt (B) and alternator stay mounting bolt (C) using power tools, then remove alternator stay (2).
10. Remove alternator mounting bolt (D), using power tools.
11. Remove alternator assembly downward from the vehicle.

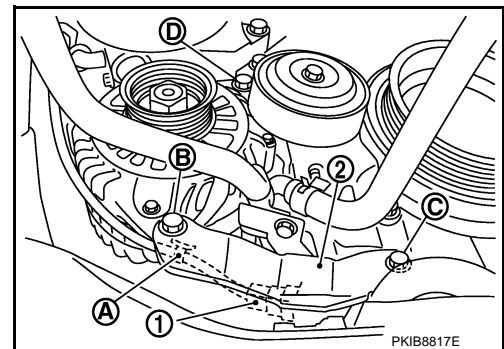

Removal (AWD Models)

CHARGING SYSTEM

< SERVICE INFORMATION >

1. Disconnect the battery cable from the negative terminal.
2. Remove power steering oil reservoir tank from the bracket.
3. Remove the clips (A) and the hose clamp (B) from the harness bracket (1).

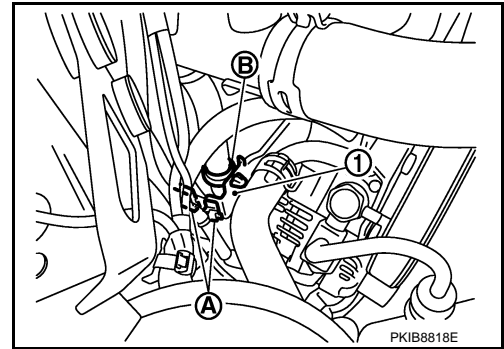

4. Remove engine front undercover, using power tools.
5. Remove alternator and power steering oil pump belt. Refer to [EM-15](#).
6. Remove alternator mounting bolt (A) and alternator stay mounting bolt (B) using power tools, then remove alternator stay (1).
7. Remove alternator mounting bolt (C), using power tools.

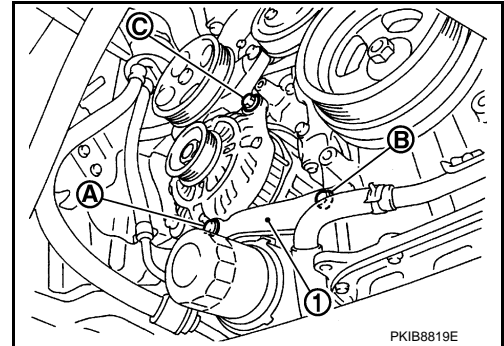

8. Pull and turn alternator, and then remove the harness bracket bolts (A).
9. Disconnect alternator connector (1).
10. Remove "B" terminal nut (2).
11. Remove alternator assembly downward from the vehicle.

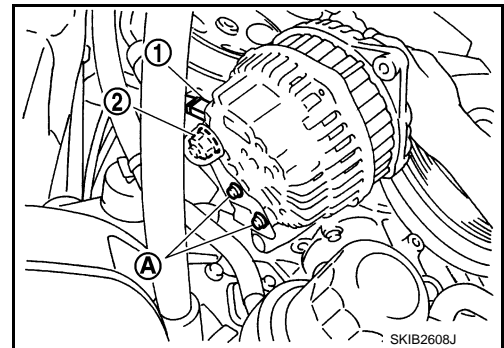

Alternator Pulley Inspection

Perform the following.

- Make sure that alternator pulley does not rattle.
- Make sure that alternator pulley nut is tight.

Alternator pulley nut:

: 118 N·m (12.0 kg·m, 87 ft·lb)

Installation

Installation is the reverse order of removal.

CAUTION:

Be sure to tighten "B" terminal nut carefully.

- Install alternator, and check tension of belt. Refer to [EM-15, "Checking Drive Belts"](#).
- For this model, the power generation voltage variable control system that controls the power generation voltage of the alternator has been adopted. Therefore, the power generation voltage variable control system operation inspection should be performed after replacing the alternator, and then make sure that the system operates normally. Refer to [SC-27, "Power Generation Voltage Variable Control System Operation Inspection"](#).

VK45DE ENGINE MODELS

CHARGING SYSTEM

< SERVICE INFORMATION >

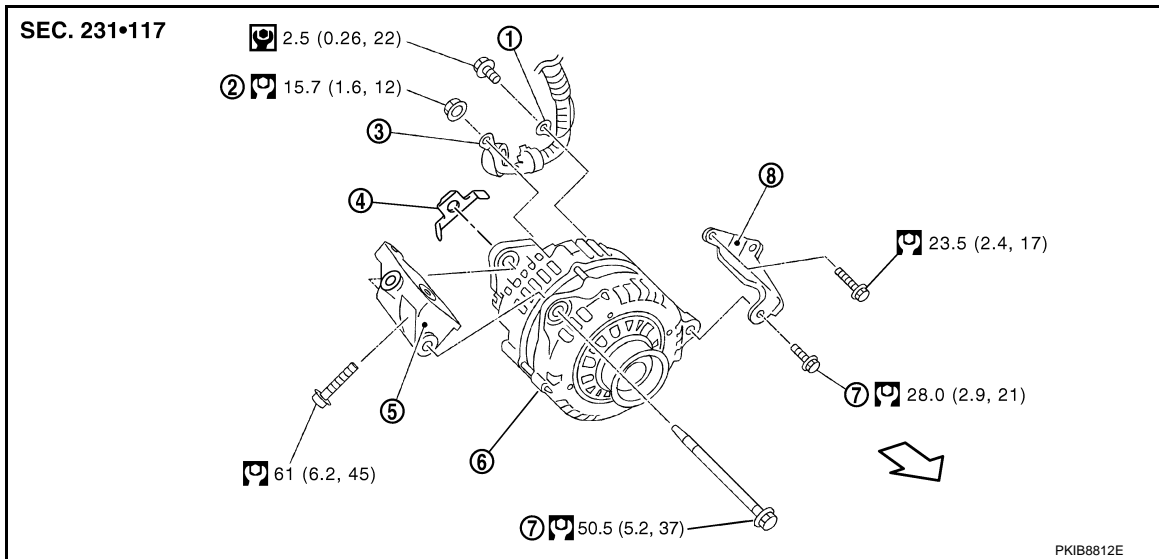

- | | | |
|------------------------------|-----------------------|-------------------------|
| 1. Alternator ground harness | 2. "B" terminal nut | 3. "B" terminal harness |
| 4. Alternator nut | 5. Alternator bracket | 6. Alternator |
| 7. Alternator mounting bolt | 8. Alternator stay | |
- : N-m (kg-m, in-lb)
 : N-m (kg-m, ft-lb)
 : Engine front

Removal

1. Disconnect the battery cable from the negative terminal.
2. Remove engine front undercover, using power tools.
3. Remove "B" terminal nut (1).
4. Disconnect alternator connector (2).
5. Remove alternator ground harness mounting bolt (3).
6. Remove the harness bracket bolts (A).

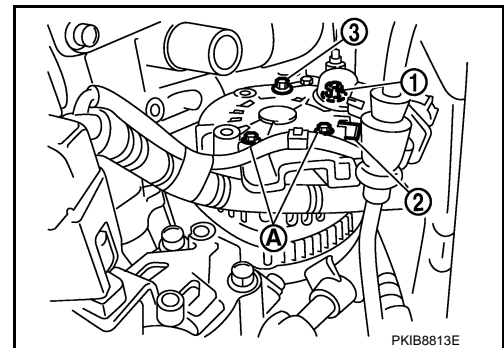

7. Remove air intake duct. Refer to [EM-175](#).
8. Remove alternator, water pump and A/C compressor belt. Refer to [EM-172](#).
9. Remove power steering oil reservoir tank (1) from the bracket, engine coolant reservoir tank (2) and vacuum tank (3).
10. Remove the harness clips (A).
11. Remove alternator mounting bolts (B), using power tools.
12. Remove alternator assembly upward.

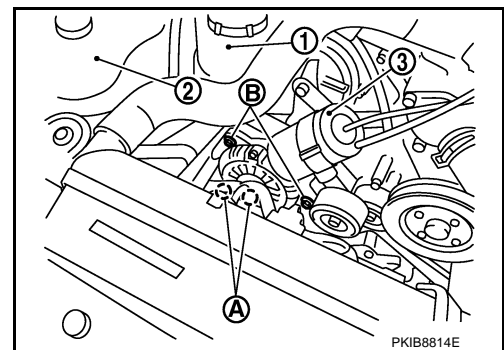

Alternator Pulley Inspection

Perform the following.

- Make sure that alternator pulley does not rattle.
- Make sure that alternator pulley nut is tight.

CHARGING SYSTEM

< SERVICE INFORMATION >

Alternator pulley nut:

: 118 N·m (12.0 kg-m, 87 ft-lb)

Installation

Installation is the reverse order of removal.

CAUTION:

Be sure to tighten "B" terminal nut carefully.



- Install alternator, and check tension of belt. Refer to [EM-172. "Checking Drive Belts"](#).
- For this model, the power generation voltage variable control system that controls the power generation voltage of the alternator has been adopted. Therefore, the power generation voltage variable control system operation inspection should be performed after replacing the alternator, and then make sure that the system operates normally. Refer to [SC-27. "Power Generation Voltage Variable Control System Operation Inspection"](#).

Disassembly and Assembly

INFOID:000000002956655

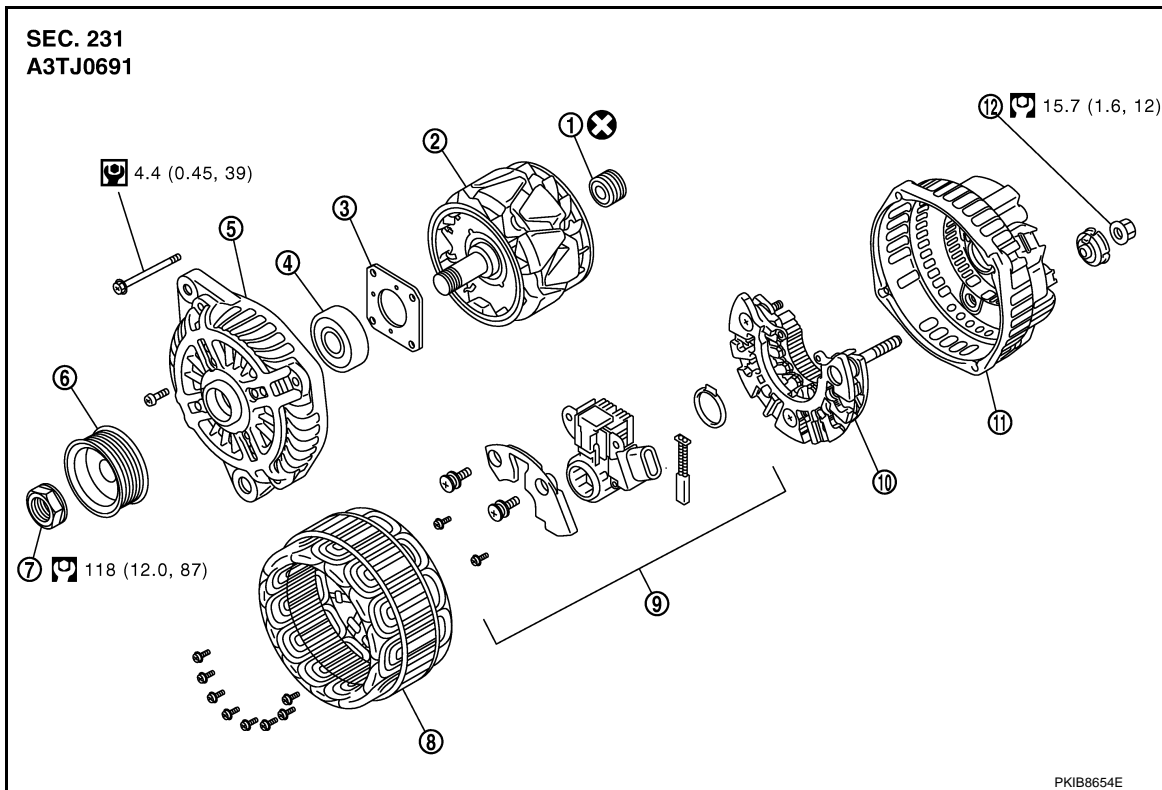
VQ35DE ENGINE MODELS



- | | | |
|--------------------|---------------------------|----------------------------------|
| 1. Rear bearing | 2. Rotor assembly | 3. Retainer |
| 4. Front bearing | 5. Front bracket assembly | 6. Pulley |
| 7. Pulley nut | 8. Stator assembly | 9. IC voltage regulator assembly |
| 10. Diode assembly | 11. Rear bracket assembly | 12. "B" terminal nut |
-  : N·m (kg-m, in-lb)
-  : N·m (kg-m, ft-lb)
-  : Always replace after every disassembly.

VK45DE ENGINE MODELS

CHARGING SYSTEM

< SERVICE INFORMATION >

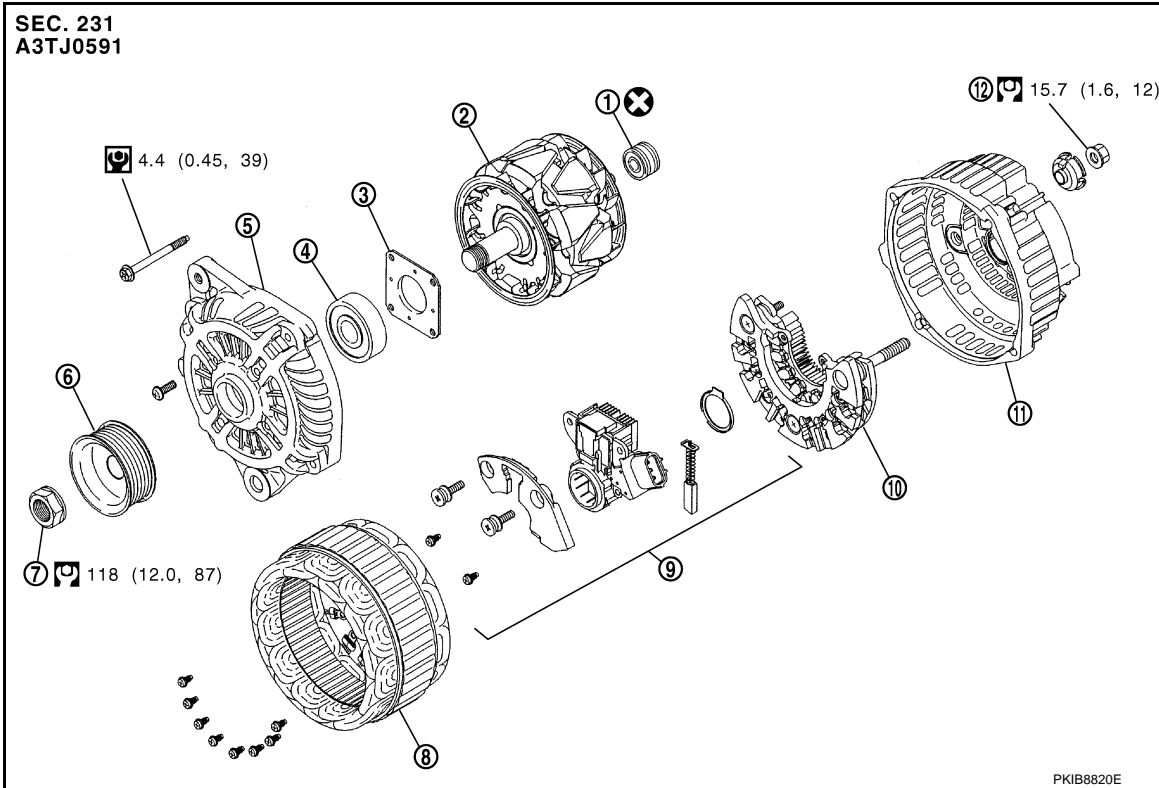

- 1. Rear bearing
 - 4. Front bearing
 - 7. Pulley nut
 - 10. Diode assembly
- : N·m (kg-m, in-lb)

- 2. Rotor assembly
 - 5. Front bracket assembly
 - 8. Stator assembly
 - 11. Rear bracket assembly
- : N·m (kg-m, ft-lb)

- 3. Retainer
 - 6. Pulley
 - 9. IC voltage regulator assembly
 - 12. "B" terminal nut
- : Always replace after every disassembly.

A
B
C
D
E
F
G
H
I
J
SC
L
M
N
O
P

SERVICE DATA AND SPECIFICATIONS (SDS)

< SERVICE INFORMATION >

SERVICE DATA AND SPECIFICATIONS (SDS)

Battery

INFOID:000000002956656

Type		110D26L
20 hour rate capacity	[V - Ah]	12 - 75
Cold cranking current (For reference value)	[A]	720

Starter

INFOID:000000002956657

Applied model		VK45DE	VQ35DE	
			2WD	AWD
		M2T85771	S114-880	S114-881
Type		mitsubishi make	HITACHI make	
		Reduction gear type		
System voltage	[V]	12		
No-load	Terminal voltage	[V]	11	
	Current	[A]	Less than 145	Less than 90
	Revolution	[rpm]	More than 3,300	More than 2,880
Minimum diameter of commutator	[mm (in)]	31.4 (1.236)	28.0 (1.102)	
Minimum length of brush	[mm (in)]	11.0 (0.433)	10.5 (0.413)	
Brush spring tension	[N (kg, lb)]	26.7 - 36.1 (2.72 - 3.68, 6.80 - 8.12)	16.2 (1.65, 3.6)	
Clearance between bearing metal and armature shaft	[mm (in)]	Less than 0.2 (0.008)		
Clearance between pinion front edge and pinion stopper	[mm (in)]	0.5 - 2.0 (0.020 - 0.079)	0.3 - 2.5 (0.012 - 0.098)	

Alternator

INFOID:000000002956658

Applied model		VK45DE	VQ35DE
Type		A3TJ0591	A3TJ0691
		mitsubishi make	
Nominal rating	[V - A]	12 - 150	
Ground polarity		Negative	
Minimum revolution under no-load (When 13.5 V is applied)	[rpm]	Less than 1,300	
Hot output current (When 13.5 V is applied)	[A/rpm]	More than 35/1,300 More than 105/2,500 More than 136/5,000	
Regulated output voltage	[V]	14.1 - 14.7 *	
Minimum length of brush	[mm (in)]	More than 5.00 (0.197)	
Brush spring pressure	[N (g, oz)]	4.1 - 5.3 (418 - 540, 14.8 - 19.1)	
Slip ring minimum outer diameter	[mm (in)]	More than 22.1 (0.870)	
Rotor (Field coil) resistance	[Ω]	1.6 - 2.0	

*: Adjustment range of power generation voltage variable control is 11.4 - 15.6 V.